

GAS PRESSURE REGULATOR AND FILTER CATALOG

11th Edition

MAXITROL[®]

www.maxitrol.com

⚠ WARNING

Service and installation must be performed by a trained/experienced service technician.

All products used with combustible gas **must** be installed and used **strictly** in accordance with the instructions of the Original Equipment Manufacturer (OEM) and with all applicable government codes and regulations, e.g. plumbing, mechanical, and electrical codes and practices. All Maxitrol products should be installed and operated in accordance with Maxitrol Safety Warning Instructions.

Maxitrol is NOT responsible for any errors or omissions in reliance by anyone of any information set forth in this catalog without additional reference to local requirements and applicable ordinances or codes.

The products in this catalogue comply with EU legislation. The technical specifications refer to the CE certification. Additional international approvals and certifications, e.g., CSA and UL, are available upon request.



CONTENT

GAS PRESSURE REGULATORS

RVLM Series – Rubber Seat Poppet Design	2
RV Series – Straight-Thru-Flow Design	4
325 Series – Lever Acting Design	6
R/RS Series – Balanced Valve Design	8
210 Series – Balanced Valve Design	10
RZ and 210Z Series – Zero Governor Design	12

SPRING SELECTION

Spring Selection Chart	15
------------------------------	----

ACCESSORIES

Vent Limiting Device: ∇ Limiter	16
Pressure Tap	16
Dust Cap	16
Tamper Proof Seals	16

SIZING A REGULATOR

System Requirements	17
---------------------------	----

FLOW CHARTS GAS PRESSURE REGULATORS

RVLM Series – Rubber Seat Poppet Design	18
RV Series – Straight-Thru-Flow Design	19
325 Series – Lever Acting Design	20
RS/RZ Series – Balanced Valve and Zero Governor Design	21
210/210Z Series – Balanced Valve and Zero Governor Design	22

DEFINITIONS

Definitions	23
-------------------	----

GAS & AIR FILTERS

HF2000 Series	24
GF1000 Series	26

FLOW CHARTS GAS & AIR FILTERS

HF2000 Series	28
GF1000 Series	29

HF2000 SERIES

GAS & AIR FILTERS

Gas and air filters protect downstream controls (regulators, automatic shut-off valves) from particulate contamination. Recommended for use upstream of fittings, regulators, and controls. Applications for the residential, commercial cooking, process heating, and industrial burner industries.

Specifications

- **Pipe Sizes:**
 - Rp ½ to Rp 2 threaded connections according to ISO 7-1/EN10226-1
 - DN25 to DN150 flanged connections according to ISO 7005-2, PN 16
- **Housing Material:** Aluminum
- **Internal Components Material:** Aluminium, elastomer, galvanized wire mesh
- **Filter Insert:** Filter mat material will not allow particle infiltration equal or exceeding 50 µm (0.05 mm)
- **Filter Mat Material:** Polypropylene fleece
- **Mounting:** Suitable for multi-positional mounting, preferably with lid facing down or to the side to facilitate removal of debris during maintenance.
- **Construction and Design/Certifications:** Function according to DIN 3386, Gas Appliances Regulation (EU) 2016/426 and Pressure Equipment Directive 2014/68/EU
- **Fuel Gases:** Suitable for gases of EN 437
- **Maximum Inlet Pressure:**
 - Threaded models: 100 kPa, 400 kPa
 - Flanged models: 100 kPa, 400 kPa, 600 kPa
- **Ambient Temperature Range:** -20 to 80 °C
- **Pressure Tap:** optional (depending on selected model)

Gas Filter Service Kit

(incl. Insert, Gasket, and Screws)

Model	Service Kit Number	Min. Order Quantity
GF40M-44...	KIT-GF40M	10
GF60M-66...	KIT-GF60M	
GF60M-88...		
GF80M-1010...	KIT-GF80M	
GF80M-1212...		
GF80M-1616...		
GF25MF-88...	KIT-GF60M	

HF2000F80...	KIT-GF80MF*	5
HF2000F100...	KIT-GF100MF*	3
GF125MF-4040...	KIT-GF125MF*	2
GF150MF-4848...	KIT-GF150MF*	

* Screws not included

Filter Inserts

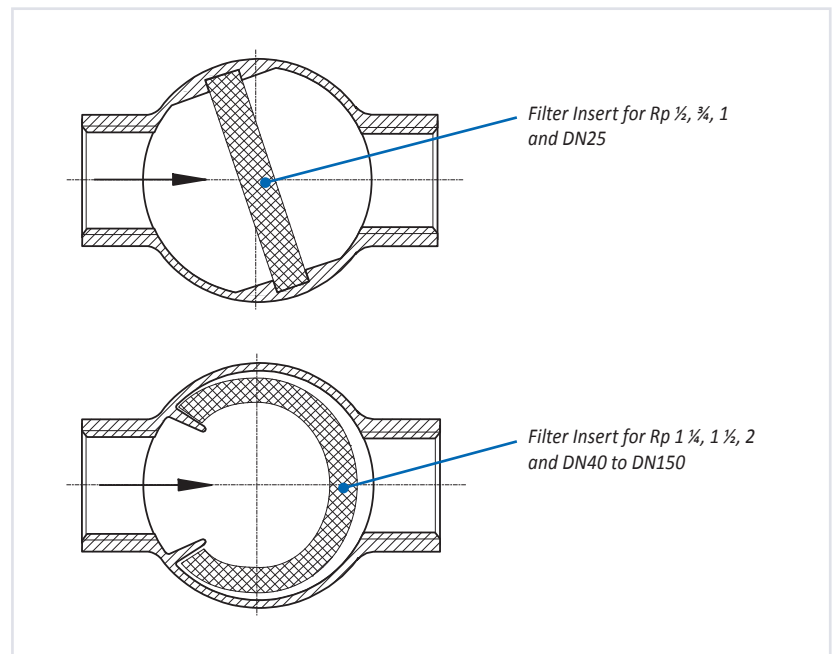

Dimensions

Model	Connection	Pipe Size	Space for filter mat replacement S	Dimensions			
				A	B	C	D (flanged)
GF40M-44...	Thread	Rp ½	60 mm	53 mm	69 mm	58 mm	-
GF60M-66...		Rp ¾	100 mm	94 mm	110 mm	94 mm	-
GF60M-88...		Rp 1	100 mm	94 mm	110 mm	94 mm	-
GF80M-1010...		Rp 1 ¼	150 mm	126 mm	157 mm	160 mm	-
GF80M-1212...		Rp 1 ½	150 mm	126 mm	157 mm	160 mm	-
GF80M-1616...		Rp 2	150 mm	126 mm	157 mm	160 mm	-
GF25MF-88...	Flange	DN25	100 mm	115 mm	165 mm	115 mm	14 mm
HF2000F80...		DN80	200 mm	204 mm	284 mm	215 mm	18 mm
HF2000F100...		DN100	220 mm	225 mm	339 mm	270 mm	18 mm
GF125MF-4040...		DN125	270 mm	268 mm	400 mm	323 mm	18 mm
GF150MF-4848...		DN150	310 mm	308 mm	448 mm	363 mm	22 mm

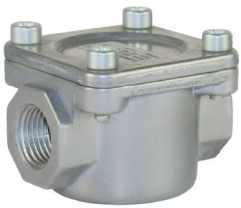

▲ GF40M...



▲ GF60M...



▲ GF80M...

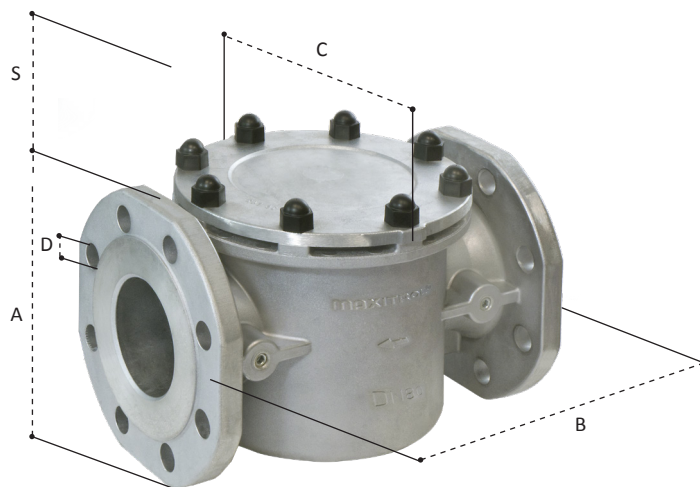

▲ HF2000F80..., HF2000F100...,
GF125MF..., GF150MF...

NOTE: Dimensions are maximums and to be used only as an aid in designing clearance for the filter. Actual production dimensions may vary somewhat from those shown.

FLOW CHARTS GAS & AIR FILTERS

HF2000 Series

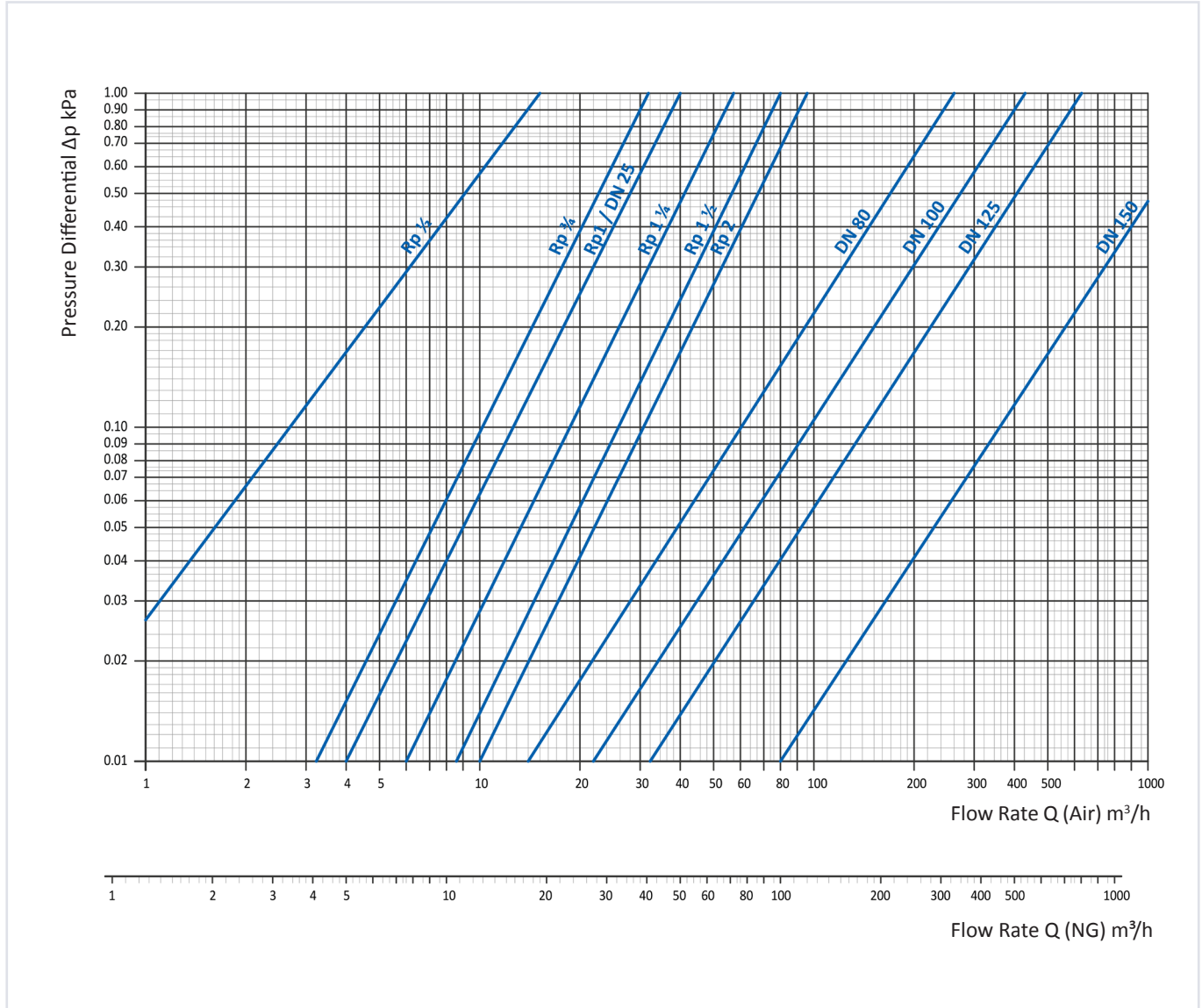

LEGEND FOR FLOW CHARTS

- Δp = Pressure Differential in kPa
- Q = Flow Rate in m^3/h
- dv = Volumetric Rate of Flow
- f = Friction Factor
- ρ = Density

Pressure Units: 1 kPa = 10 mbar = 10 hPa
 Air: $dv = 1.00$ f = 1.00
 Natural Gas (NG): $dv = 0.64$ f = 1.24
 Liquid petroleum gas (LPG): $dv = 1.56$ f = 0.80

$$dv = \frac{\rho_{gas}}{\rho_{air}}$$

$$f = \sqrt{\frac{\rho_{air}}{\rho_{gas}}}$$

$$\dot{V}_{gas} = f \cdot \dot{V}_{air}$$

NOTE: The given flow rates are approximate values. Actual flow rates may vary somewhat from those shown.

MAXITROL®

© 2022 Maxitrol GmbH & Co. KG, All Rights Reserved.

Maxitrol Company

23555 Telegraph Road
Southfield, MI 48033
USA

T: (+1) 248 356-1400
infoNA@maxitrol.com

Maxitrol GmbH & Co. KG

Warnstedter Str. 3
06502 Thale
Germany

T: (+49) 3947 400-0
infoEU@maxitrol.com

Maxitrol GmbH & Co. KG

Valleys Innovation Centre
Navigation Park
Abercynon CF45 4SN
United Kingdom

T: (+44) 1443 742-755
M: (+44) 7866 492-261
infoEU@maxitrol.com

Maxitrol GmbH & Co. KG

Industriestr. 1
48308 Senden
Germany

T: (+49) 2597 9632-0
senden@maxitrol.com