

SENTRY GS

EXCESS FLOW VALVES FOR
GAS SERVICE LINES

MAXITROL®

www.maxitrol.com

CONTENTS

- 1 DESCRIPTION
FUNCTION
- 2 TECHNICAL DATA
CALIBRATION
- 3 APPLICATION AND INSTALLATION
FEATURES AND ADVANTAGES
- 4 TYPE DESIGNATION
SPECIAL TYPES
- 5 TYPE LABEL AND ID-CARD
DEFINITIONS
- 6 PERFORMANCE GRAPHS – TYPE B
- 8 PERFORMANCE GRAPHS – TYPE D
- 10 PERFORMANCE GRAPHS – TYPE Z
- 12 ORDER CODE

DESCRIPTION

Excess flow valves are designed to close, shutting of the gas flow, when a predefined flow rate is reached. Gas utilities use excess flow valves as a preventive measure to reduce the possibility of damage or injury in the case of a break in the gas service line. Gas installation regulations in Germany require the installation of an automatically closing device (e. g. excess flow valve) in the gas service line.

SENTRY GS excess flow valves have been used effectively for more than 30 years in underground gas service lines throughout the world. In Germany alone, millions of Maxitrol excess flow valves (underground and residential) are currently in service. Maxitrol offers a complete range of excess flow valves from DN15 to DN50 for different operating pressure ranges.

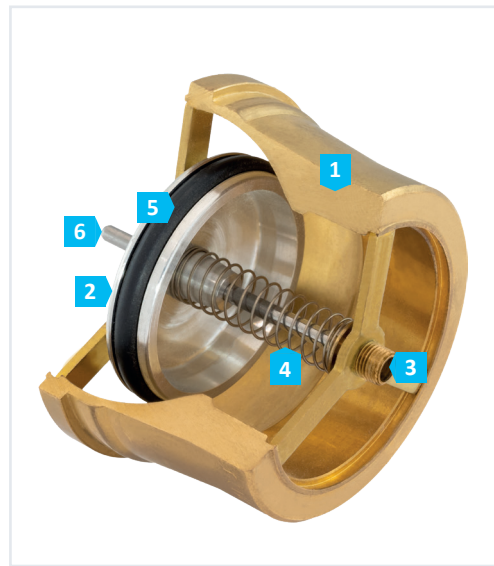

◀ Figure 1
Sectional view of a SENTRY GS in open position

- 1 Housing, Inlet and Outlet Guide (brass)
- 2 Closing Disc (standard version aluminium)
- 3 Adjusting Screw (brass)
- 4 Pressure Spring (stainless steel)
- 5 O-Ring (NBR)
- 6 Guide Pin (stainless steel)

FUNCTION

Maxitrol's factory calibration (100 %) provides a precise and reliable closing flow rate V_s . In the nominal flow range, excess flow valves remain in a stable, open position with the gas flowing through a large ring shaped gap between the closing unit and the seat (see figure 2). When the closing flow rate (V_s) is reached, the closing unit overcomes the spring pressure, and the closing unit is pressed into the valve seat, resulting in a gas-tight seal.

The SENTRY GS closes seamlessly without an intermediate position. To reopen after repair, apply pressure to the downstream side of the excess flow valve until the pressure is equalized.

If equipped with a by-pass orifice (see figure 2), SENTRY GS excess flow valves reopen automatically after the downstream line has been repaired. Open the main gas manual shutoff valve slowly.

▼ Figure 2
Functional principle of a SENTRY GS excess flow valve with a by-pass orifice (integrated in an electro fusion fitting)

- 1 By-Pass Orifice

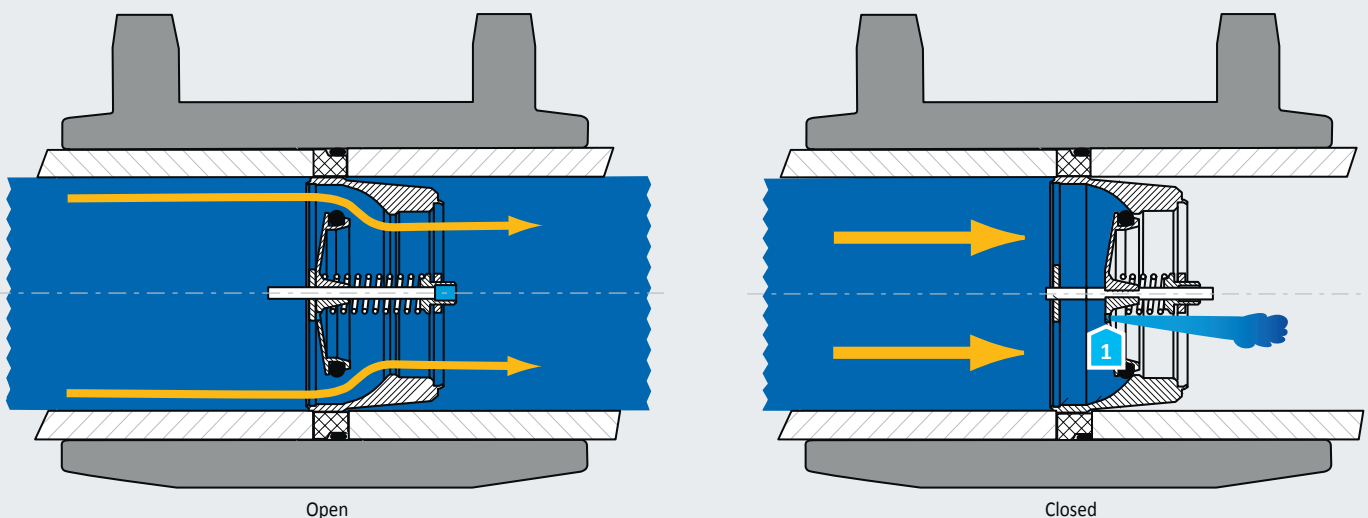

TECHNICAL DATA *See information on the type label.*

Type according to German *DIN 30652-2**, DVGW Registration DG-4360BO0438.

- **GASES:** Natural gas, propane gas and butane gas according to DIN EN 437 and *DVGW worksheet G 260/1***.
- **AMBIENT TEMPERATURE RANGE:** -20 °C to 60 °C
- **MOUNTING POSITION:** Suitable for multi-positional mounting (indicated on label). Closing flow rate V_s depends on the excess flow valve mounting position (see figure 3).
- **VERSIONS:**
 - Installed in the housing: Electro fusion fitting, PE pipe SDR11.
 - As used in other components: Mounting boss for tapping saddle and clamp for securing in the pipe.

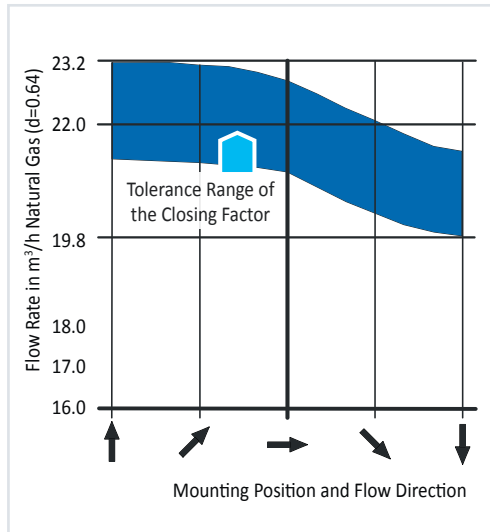

◀ **Figure 3**
Influence of mounting position on closing factor and tolerance. Example type Z in DN25

* *DIN 30652-2:*
Excerpt of DVGW-TRGI 2018 that prescribe the German standard for excess flow valves in underground service lines.

** *DVGW worksheet G 260/1:*
The quality requirements of the combustion gases are described in the DVGW worksheet G 260/1.

CALIBRATION

SENTRY GS are calibrated to a narrow tolerance by adjusting the force of the pressure spring. This improves the protection of the gas service line downstream of the excess flow valve.

Calibrated SENTRY GS with a narrower Closing Flow Range provide the following advantages:

- a) *At the same nominal flow rate, the calibrated SENTRY GS provides better protection than an uncalibrated excess flow valve (see bars 1 & 2 in figure 4).*
- b) *At the same safety level, the calibrated SENTRY GS provides for a substantially higher nominal flow rate V_N than an uncalibrated excess flow valve (see bars 1 & 3 in figure 4).*

Two peak flow values must be considered when using the SENTRY GS excess flow valve:

1. Temporary flow surge when the branch line is initially opened or reopened (e.g. a pipe segment was depressurized for repair and then repressurized, or a shut-off device downstream of the excess flow valve is closed and then reopened).
2. The peak flow at the start up of gas appliances.

These peak flow values are difficult to estimate. For this reason, calibrated excess flow valves are used most often. This is true even when the nominal flow rate of an uncalibrated excess flow valve is sufficient for the current peak flow of all downstream appliances.

Calibration provides more reserve flow rate increase than uncalibrated excess flow valves. More reserve flow rate allows for subsequent increases in the consumer's gas consumption or a change in gas type. Calibrated excess flow valves are required for gas service lines with a line pressure below 25 mbar (25 hPa).

▼ **Figure 4**
Calibrated excess flow valves compared with uncalibrated. Example Maxitrol type Z in DN25

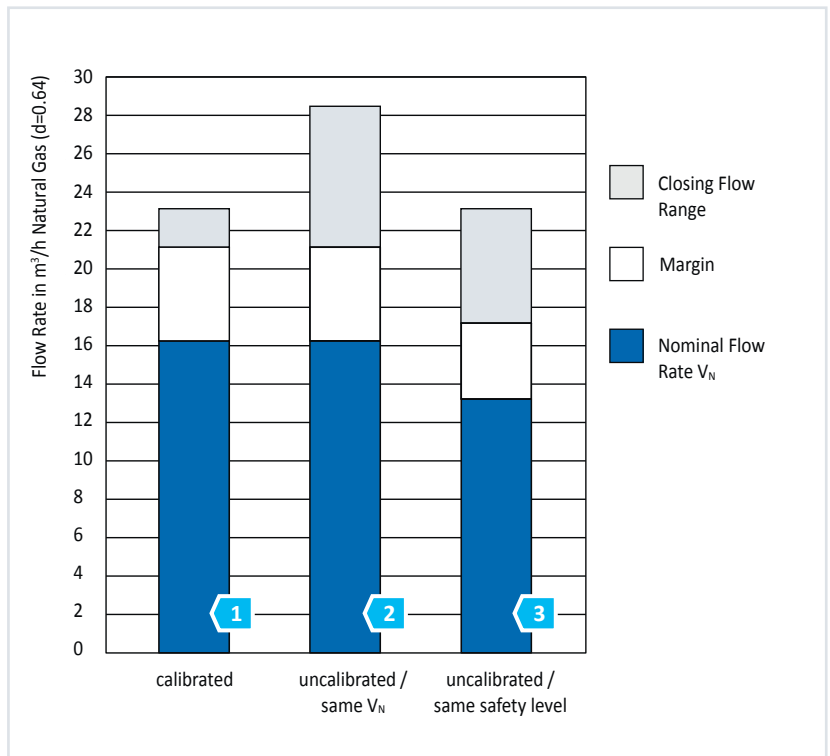

APPLICATION AND INSTALLATION

It's recommended that excess flow valves be installed in the branch line off the main gas line and in the gas service line. An excess flow valve used in the gas service line must be identified at the main gas shut-off valve of the house (ID-Card with cable tie is included, see page 5, figure 7 a, b, c).

SENTRY GS excess flow valves must be installed and used strictly in accordance with Maxitrol's instructions, with government codes and regulations, and with plumbing codes and practices. SENTRY GS excess flow valves must be correctly sized and selected according to the consumption load. The functional range of the SENTRY GS is on the type label (see page 5, figure 7 a, b, c).

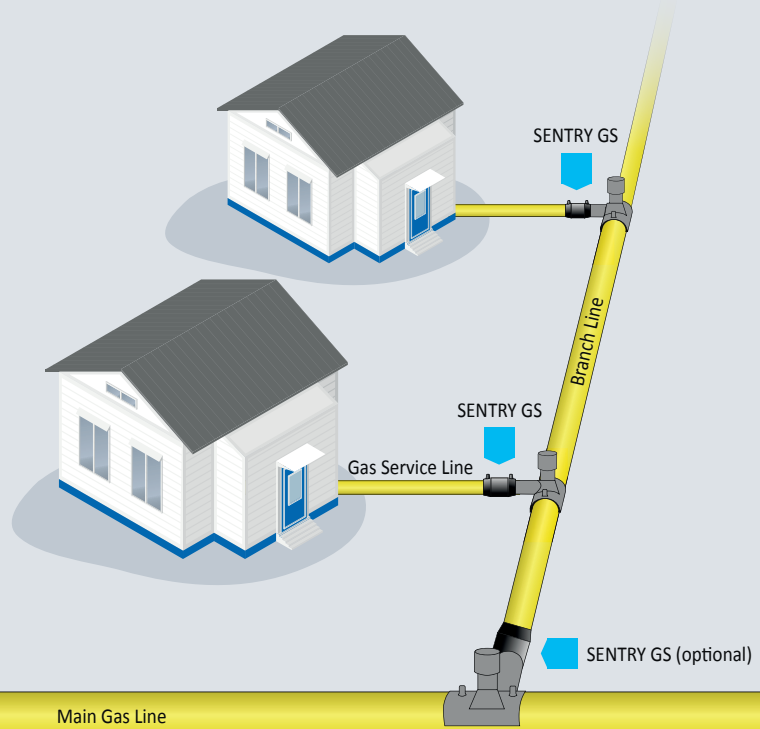

▲ Figure 5
Recommended installation
locations of the SENTRY GS

FEATURES AND ADVANTAGES

- Maxitrol has used the same materials that make up the SENTRY GS in various controls for more than 70 years. The housing is made of brass, and the closing disc is either brass or aluminium. No synthetic materials are used for components transmitting energy. Pressure springs are made of corrosion resistant stainless steel.
- Each SENTRY GS is calibrated to a narrow tolerance for a maximum closing flow rate of 1.45 times the nominal flow rate. This increases the protectable pipe length.
- The SENTRY GS is factory-tested both individually and, after being inserted into a fitting, as a complete unit.
- An installed SENTRY GS has no effect on the function of the fitting. Written confirmation from German supply pipe and fitting OEMs available upon request.
- SENTRY GS can be supplied in electro fusion couplers and reducers.
- SENTRY GS have a low pressure drop.
- SENTRY GS are largely resistant to contaminants such as dust, steel and plastic shavings (as proven in both laboratory and field tests by independent European test agencies).
- The by-pass orifice (optional) is calibrated to a narrow tolerance to ensure a quick reopening time.
- In the open position, the closing unit of the SENTRY GS covers the by-pass orifice preventing debris from collecting in the orifice.
- An optional ID card is available for each SENTRY GS (see page 5).
- SENTRY GS excess flow valves are easily traced with a barcode (optional) on the fitting.
- SENTRY GS can be special ordered to fit customer-specific installation requirements.
- Nominal sizes from DN15 (d20) to DN50 (d63)
- Operating pressure range 100 mbar to 5 bar (100 hPa to 0.5 MPa), 25 mbar to 1 bar (25 hPa to 0.1 MPa) and 35 mbar to 5 bar (35 hPa to 0.5 MPa). Higher pressure ranges available upon request.

TYPE DESIGNATION

In accordance with German *DIN 30652-2*, standard types A, B, C, and D are specified by operating pressure and closing flow rate. SENTRY GS are sized based on closing flow rates for the highest possible nominal flow rates with the lowest pressure drop. Upon request, Maxitrol can manufacture SENTRY GS types to

meet performance standards other than those of *DIN 30652-2*. The multi-range SENTRY GS..Z, for example, covers most of the current line pressures in Germany (see table 1 for types B, D (A), and Z nominal flow rates).

▼ **Table 1**
Type overview
(Nominal flow rates refer to minimal line pressure)

Type according DVGW G 5305-2, DIN 30652-2		Nominal diameter D_N (external pipe \varnothing)	Nominal flow rate V_N [m ³ /h] (air)	Nominal flow rate V_{Gas} [m ³ /h] (natural gas, $d=0.64$)	By-pass orifice (if equipped)
B	Line pressure: 100 mbar to 5 bar (100 hPa to 0.5 MPa)	DN20 (d25)	12	15	with by-pass orifice VL ≤ 30 l/h air at 5 bar (0.5 MPa)
		DN25 (d32)	20	25	
		DN32 (d40)	30	38	
		DN40 (d50)	45	56	
		DN50 (d63)	73	91	
D (A)	Line pressure: 25 mbar to 1 bar (25 hPa to 0.1 MPa)	DN20 (d25)	5	6	with by-pass orifice VL ≤ 30 l/h air at 0.1 bar (100 hPa)
		DN25 (d32)	9	11	
		DN32 (d40)	15	19	
		DN40 (d50)	22	28	
		DN50 (d63)	40	50	
Z	Line pressure: 35 mbar to 5 bar (35 hPa to 0.5 MPa)	DN20 (d25)	7	9	with by-pass orifice VL ≤ 30 l/h air at 1 bar (0.1 MPa)
		DN25 (d32)	13	16	
		DN32 (d40)	20	25	
		DN40 (d50)	32	40	
		DN50 (d63)	51	64	

SPECIAL TYPES

In addition to the standard types and the requirements of the German *DIN 30652-2*, SENTRY GS excess flow valves can be custom-made to meet customer specifications. Performance parameters of the excess flow valve can be modified, such as operating pressure, nominal and closing flow rate, or its size and shape. In cases where the performance parameters are not yet known, or an existing gas service line needs to be

retrofitted with an excess flow valve, a special in-pipe version is available. The in-pipe version is attached to a flexible shaft and inserted into the gas line (see figure 6).

Depending on nominal size, the excess flow valve can be secured in place 20 m or more from the location where it was inserted into the gas line.

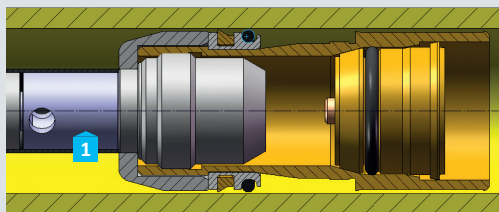

"In-pipe" EFV installation

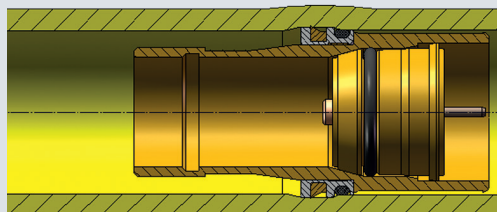

"In-pipe" EFV fixation

◀ **Figure 6**
Sectional view of an
"in-pipe" excess flow valve

1 Installation tool with flexible shaft

TYPE LABEL AND ID-CARD

An ID-Card (see figure 7 a & b), showing the product information is delivered with the standard SENTRY GS. Two type labels (see figure 7 b & c)

are located on the back of the ID-Card and on the SENTRY GS itself. The second label is self-adhesive and can be used for documentation.



◀ Figure 7
SENTRY GS ID-Card (with type label on the back) for mounting on the main gas shut-off valve; Example of a type label

- 1 Flow Direction
- 2 Operating Pressure Range p
- 3 Nominal Flow Rate Natural Gas V_{Gas}
- 4 Type Designation
- 5 By-Pass Orifice
- 6 Pattern of Manufacturing Control
- 7 Manufacturing Date (e. g. 23 = Current Week, 25 = Year 2025)
- 8 Nominal Flow Rate Air V_N

DEFINITIONS

- **PRESSURE DROP:** The pressure drop of SENTRY GS is type dependent and shown in the corresponding diagrams (DN25 and DN50 shown, other types upon request). Also shown are the performance parameters for flow rate air, flow rate gas (m^3/h) and thermal load (kW). The upper limit of allowable pressure drop of individual SENTRY GS types are defined in accordance with the *DIN 30652-2*. SENTRY GS have extremely low pressure drops allowing for high nominal flow rates.
- **PRESSURE DEPENDENCE OF FLOW RATES:** The nominal and closing flow rates are affected by changes in the line pressure that, in turn, changes the density of the flowing gas. Higher line pressures cause higher flow rates than indicated in the type overview (see table 1, page 4).
- **STANDARD VALUES FOR PROTECTABLE LINE LENGTHS:** To calculate the protectable line lengths for all SENTRY GS types, it was determined that the total drag coefficient of the tapping saddle and main gas shut-off valve is $\zeta = 20$ (basic parameters and calculation according to *DIN 30652-2*, appendix B). The standard values in the following diagrams were determined using excess flow valves in a horizontal position and commercially available PE pipes (series SDR11). If the line length is longer than the protectable line length, the size of the pipe should be increased. Due to variations in gas service line components the protectable line lengths may vary significantly in practice.
- **STANDARD VALUES FOR REOPENING TIME PER METER LINE LENGTHS:** The reopening times in the following diagrams are approximate for the indicated line pressures and a density ratio of 0.64.
- **CLOSING FACTOR (f_s):** When flow rate reaches the closing flow factor the SENTRY GS excess flow valve will close. The closing factor (f_s) is calculated by dividing the closing flow rate (V_s) by the nominal flow rate (V_N).

PERFORMANCE GRAPHS – TYPE B

PRESSURE DROP SENTRY GS25 TYPE B
(100 mbar to 5 bar / 100 hPa to 0.5 MPa)

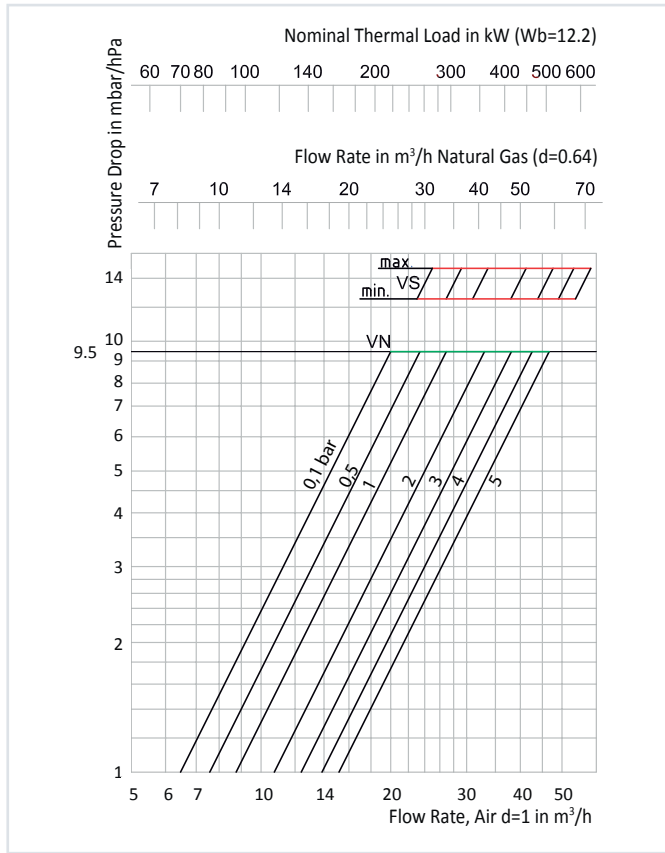

PRESSURE DROP SENTRY GS50 TYPE B
(100 mbar to 5 bar / 100 hPa to 0.5 MPa)

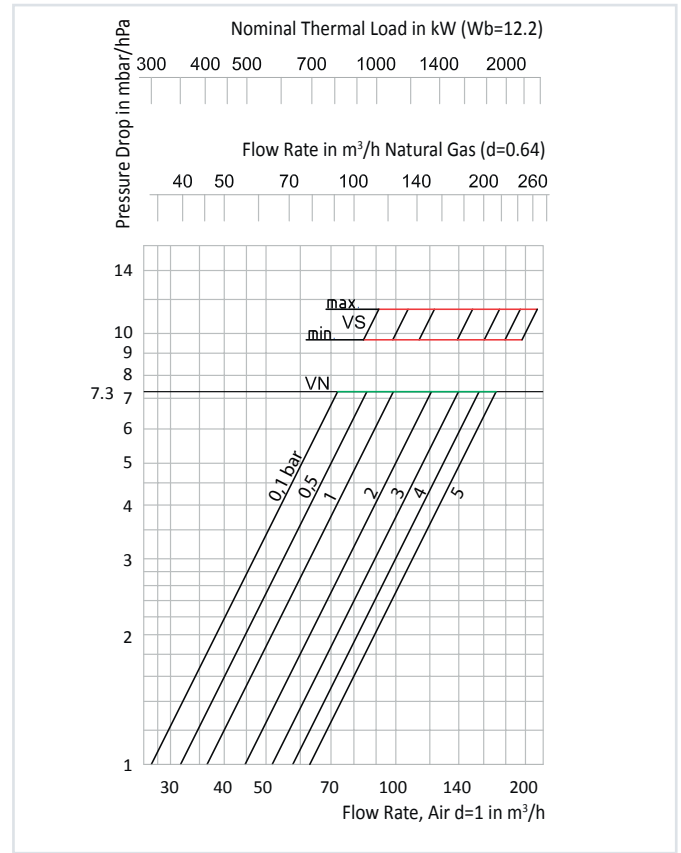

PRESSURE DEPENDENCE OF FLOW RATES SENTRY GS..B

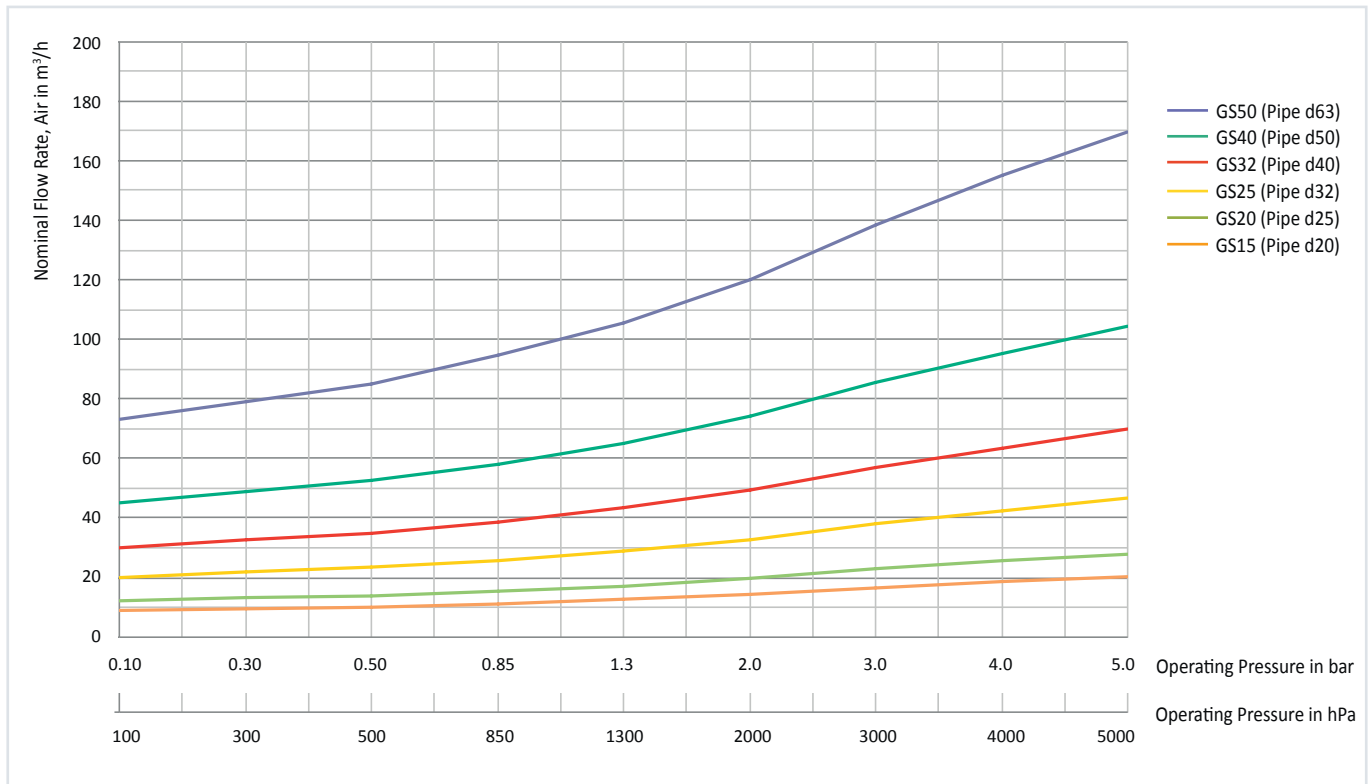

STANDARD VALUES FOR PROTECTABLE LINE LENGTHS SENTRY GS..B

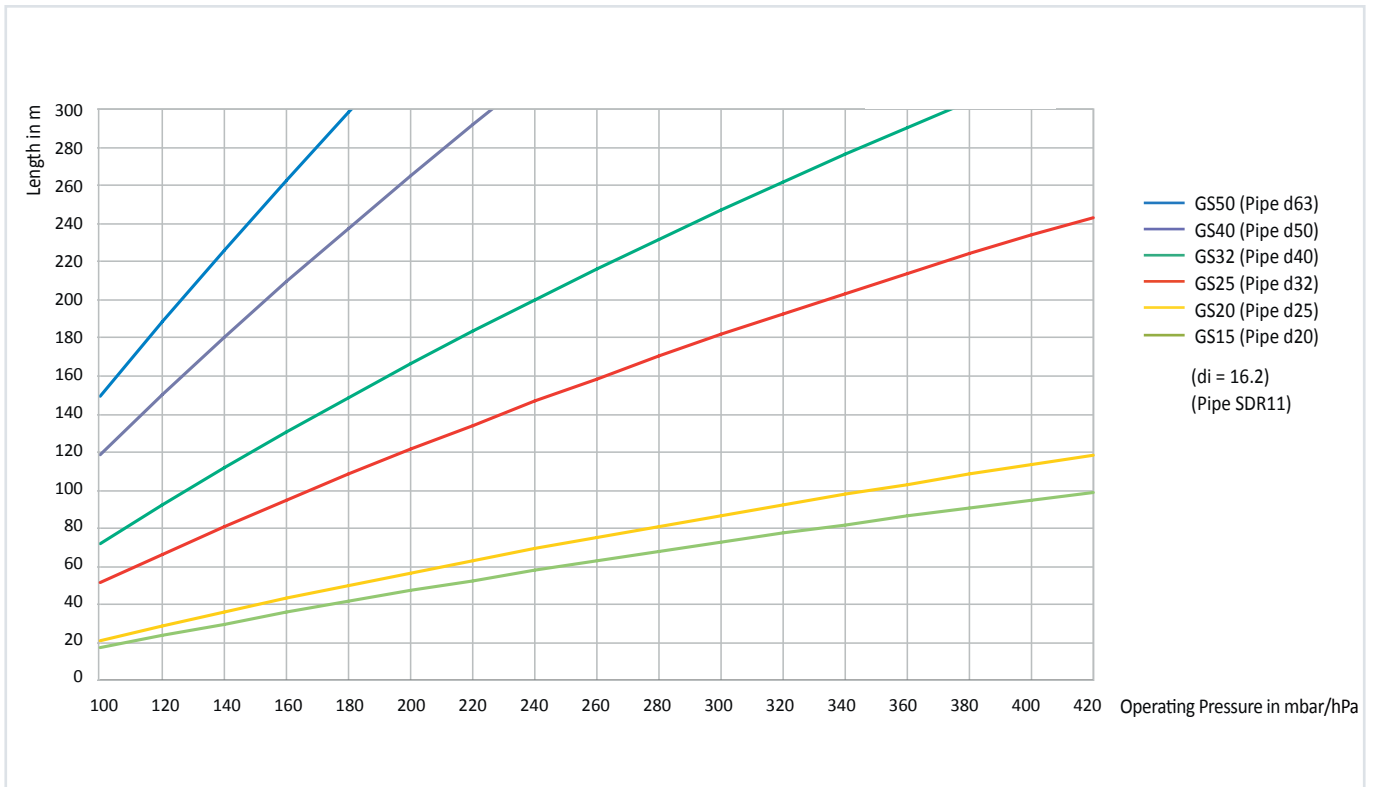

STANDARD VALUES FOR REOPENING TIME OF SENTRY GS..B (30 l/h at 5 bar / 0.5 MPa) PER METER LINE LENGTHS

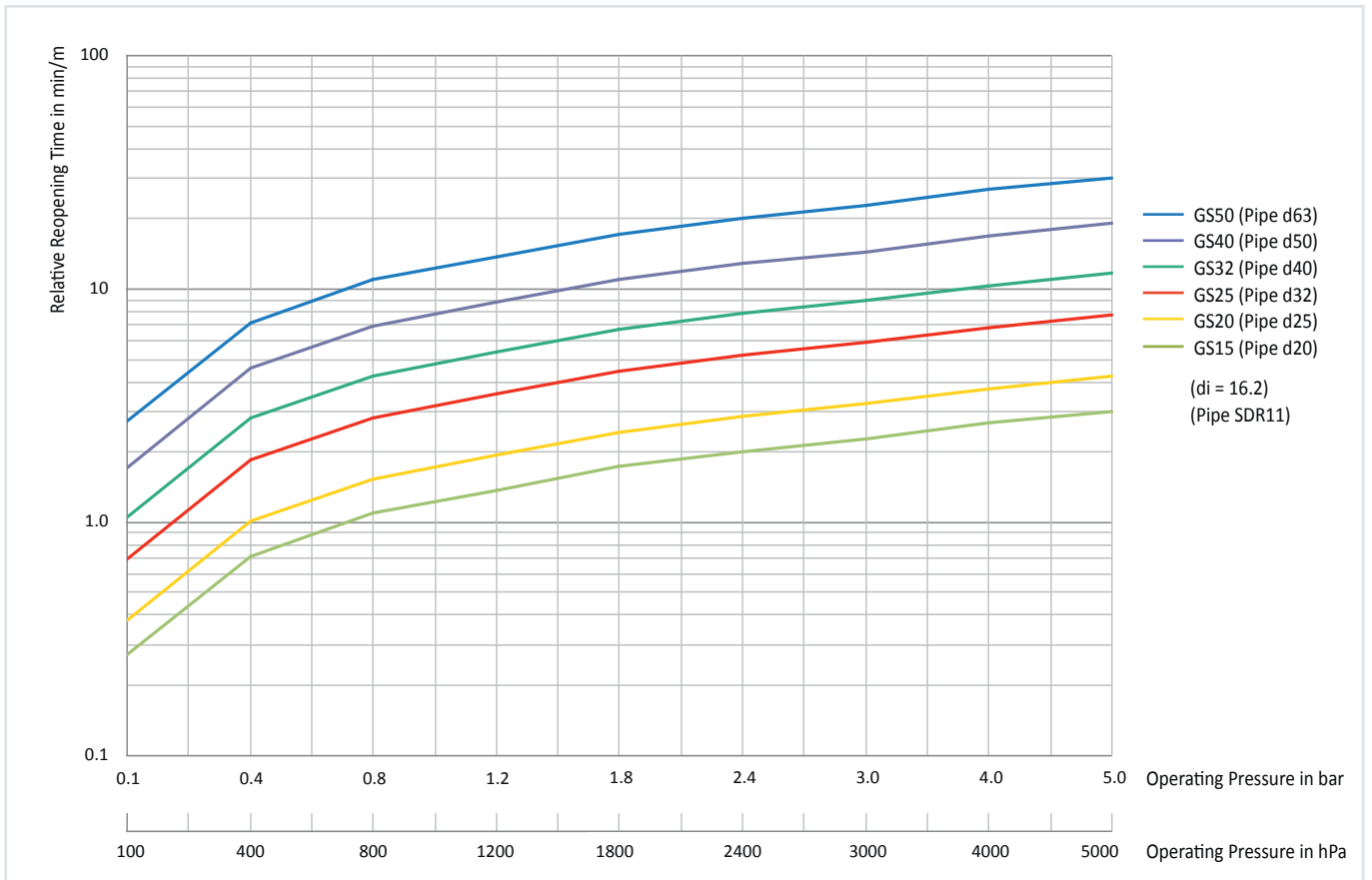

PERFORMANCE GRAPHS – TYPE D

PRESSURE DROP SENTRY GS25 TYPE D
(25 mbar to 1 bar / 25 hPa to 0.1 MPa)

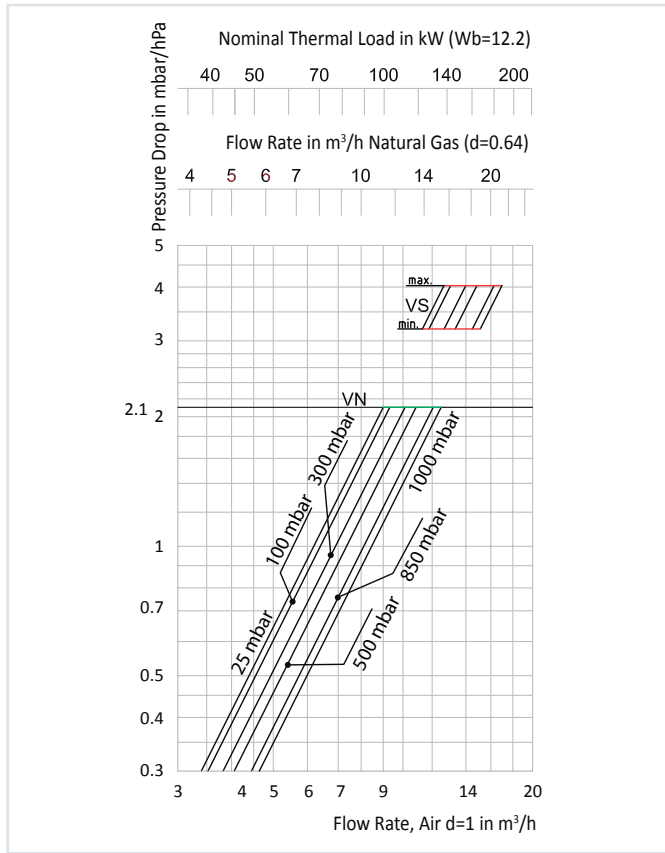

PRESSURE DROP SENTRY GS50 TYPE D
(25 mbar to 1 bar / 25 hPa to 0.1 MPa)

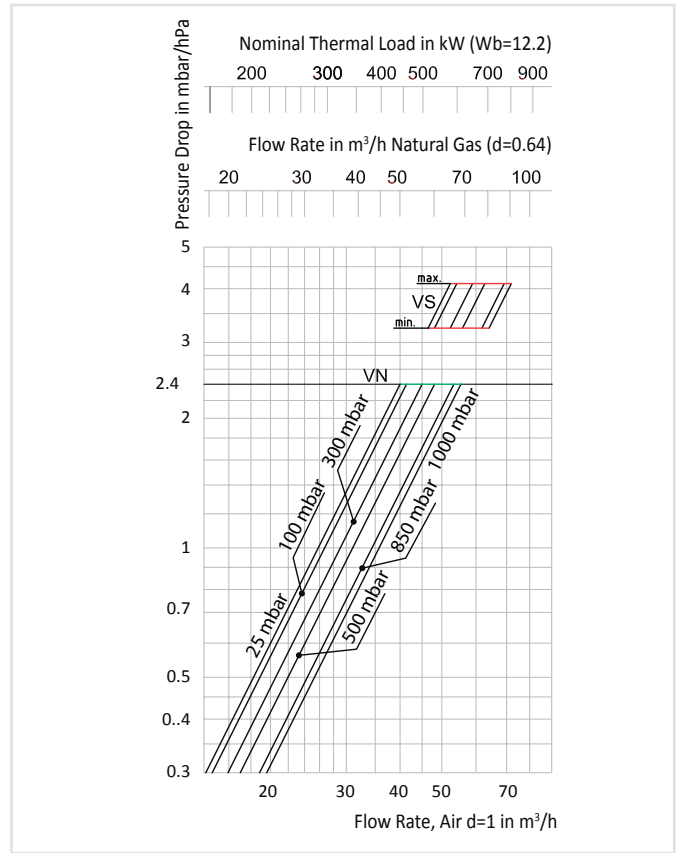

PRESSURE DEPENDENCE OF FLOW RATES SENTRY GS..D

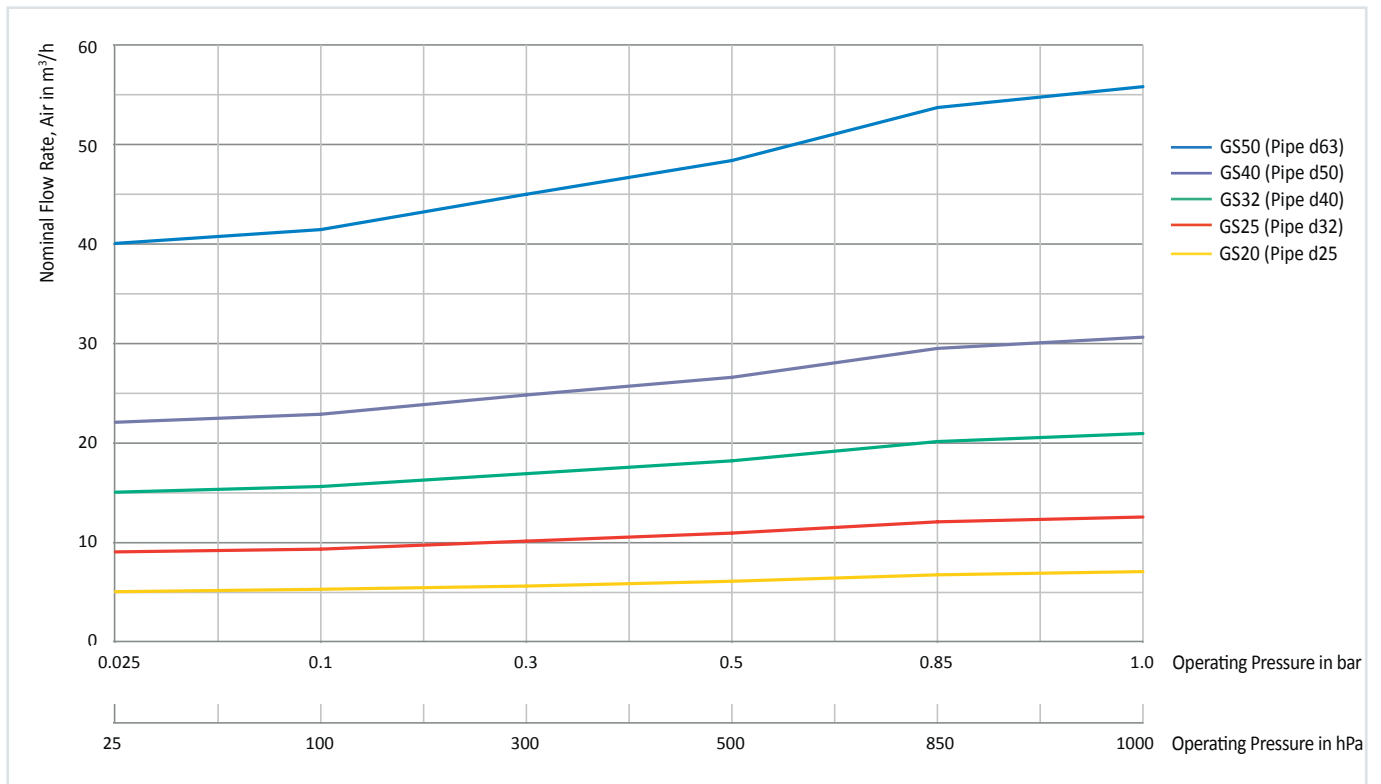

STANDARD VALUES FOR PROTECTABLE LINE LENGTHS SENTRY GS..D

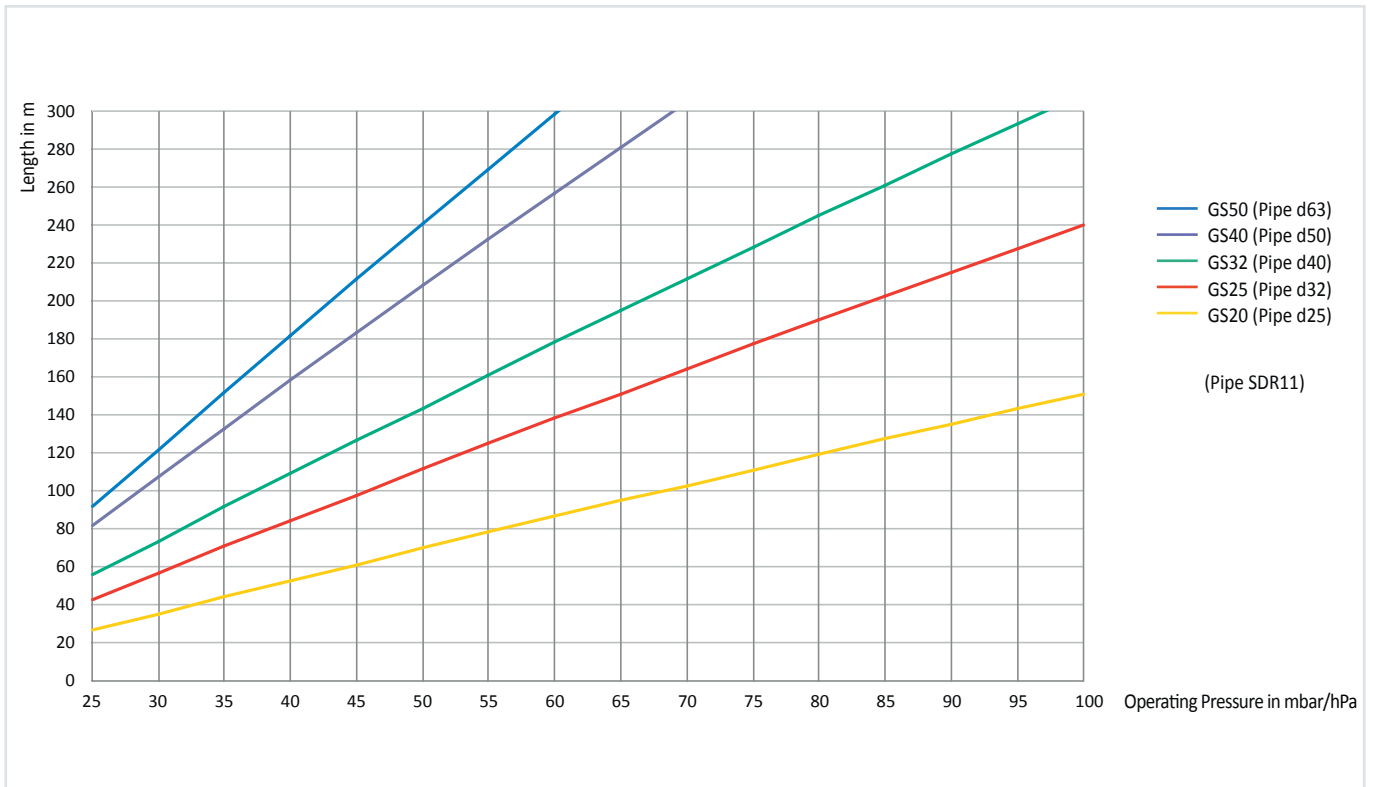

STANDARD VALUES FOR REOPENING TIME OF SENTRY GS..D (30 l/h at 100 mbar / 100 hPa) PER METER LINE LENGTHS

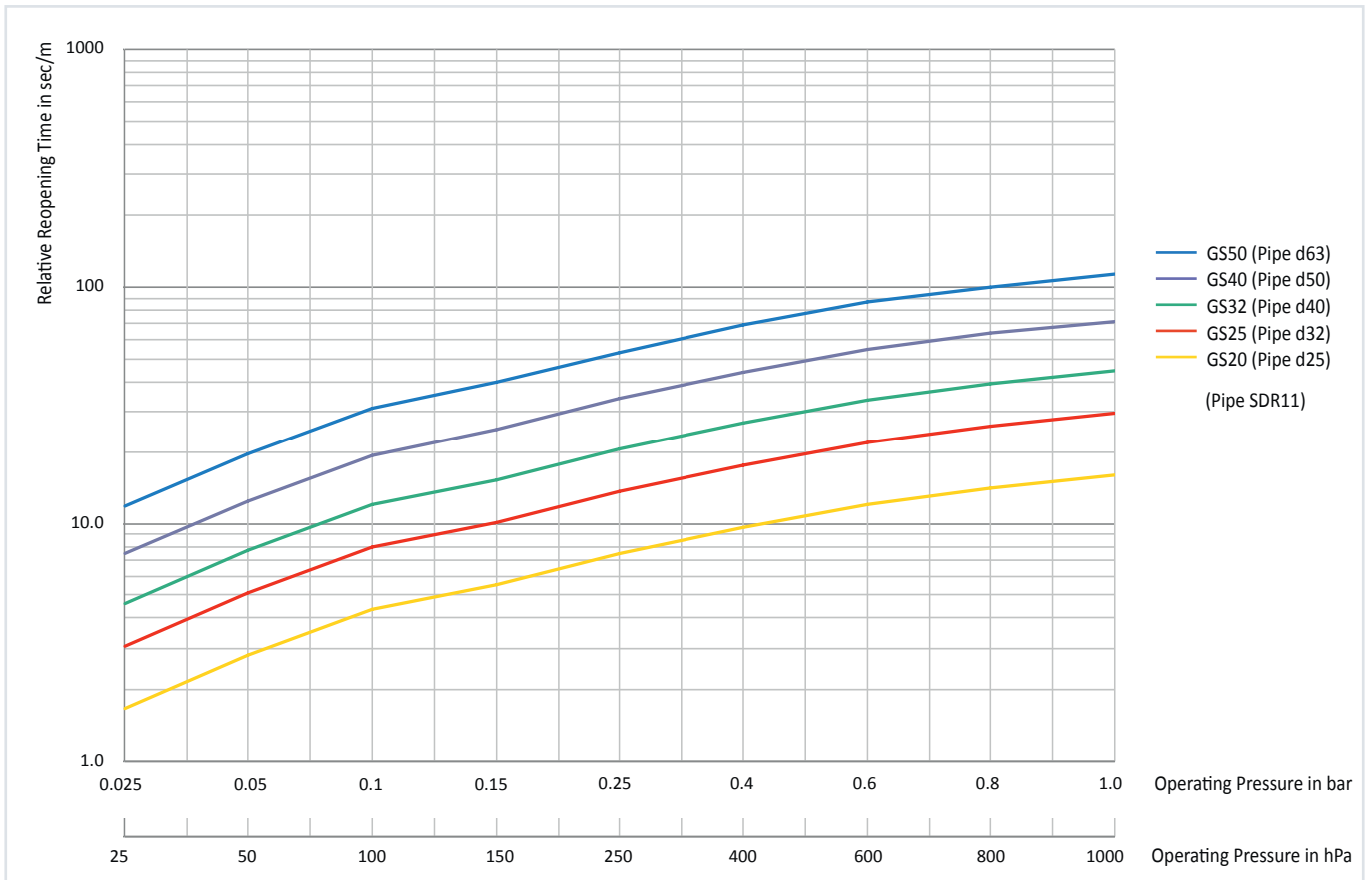

PERFORMANCE GRAPHS – TYPE Z

PRESSURE DROP SENTRY GS25 TYPE Z
(35 mbar to 5 bar / 35 hPa to 0.5 MPa)

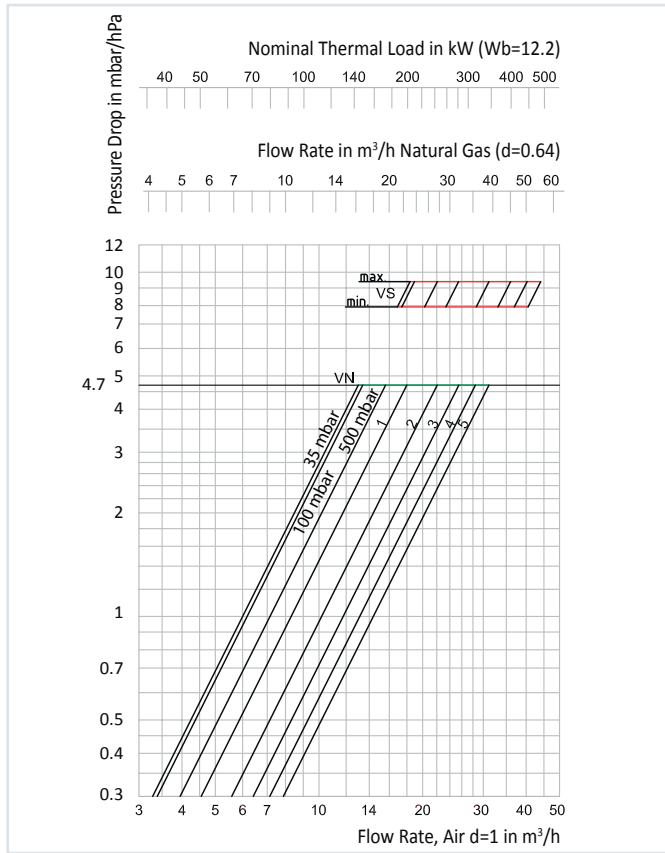

PRESSURE DROP SENTRY GS50 TYPE Z
(35 mbar to 5 bar / 35 hPa to 0.5 MPa)

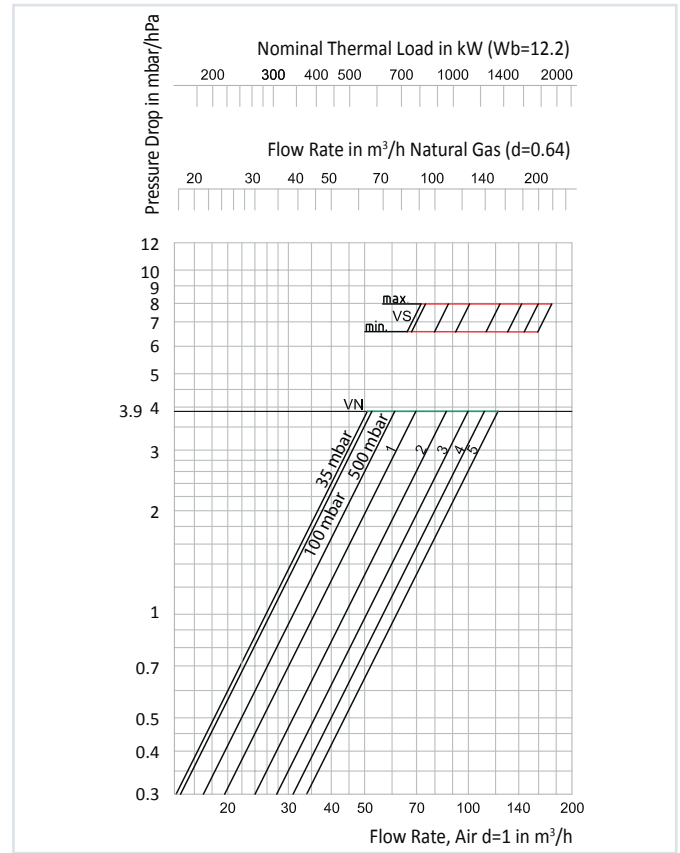

PRESSURE DEPENDENCE OF FLOW RATES SENTRY GS..Z

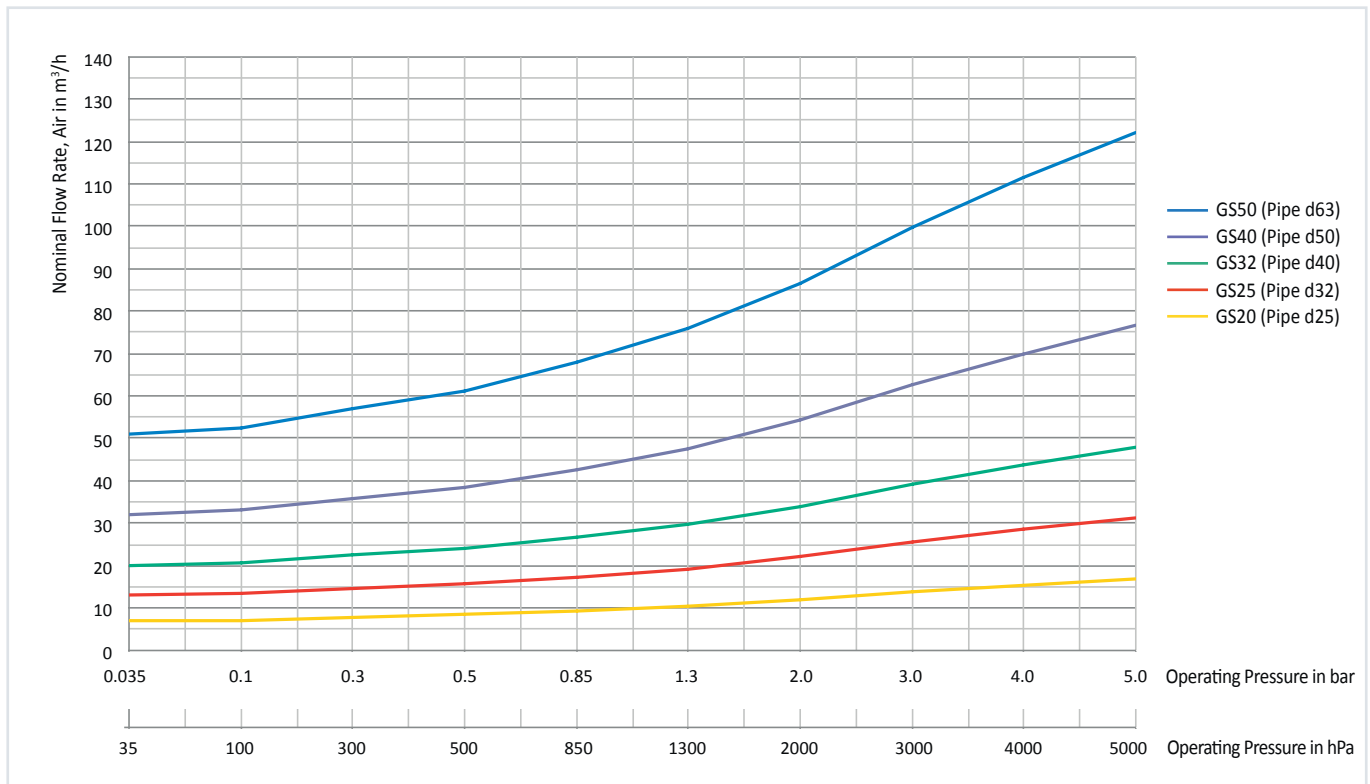

STANDARD VALUES FOR PROTECTABLE LINE LENGTHS SENTRY GS..Z

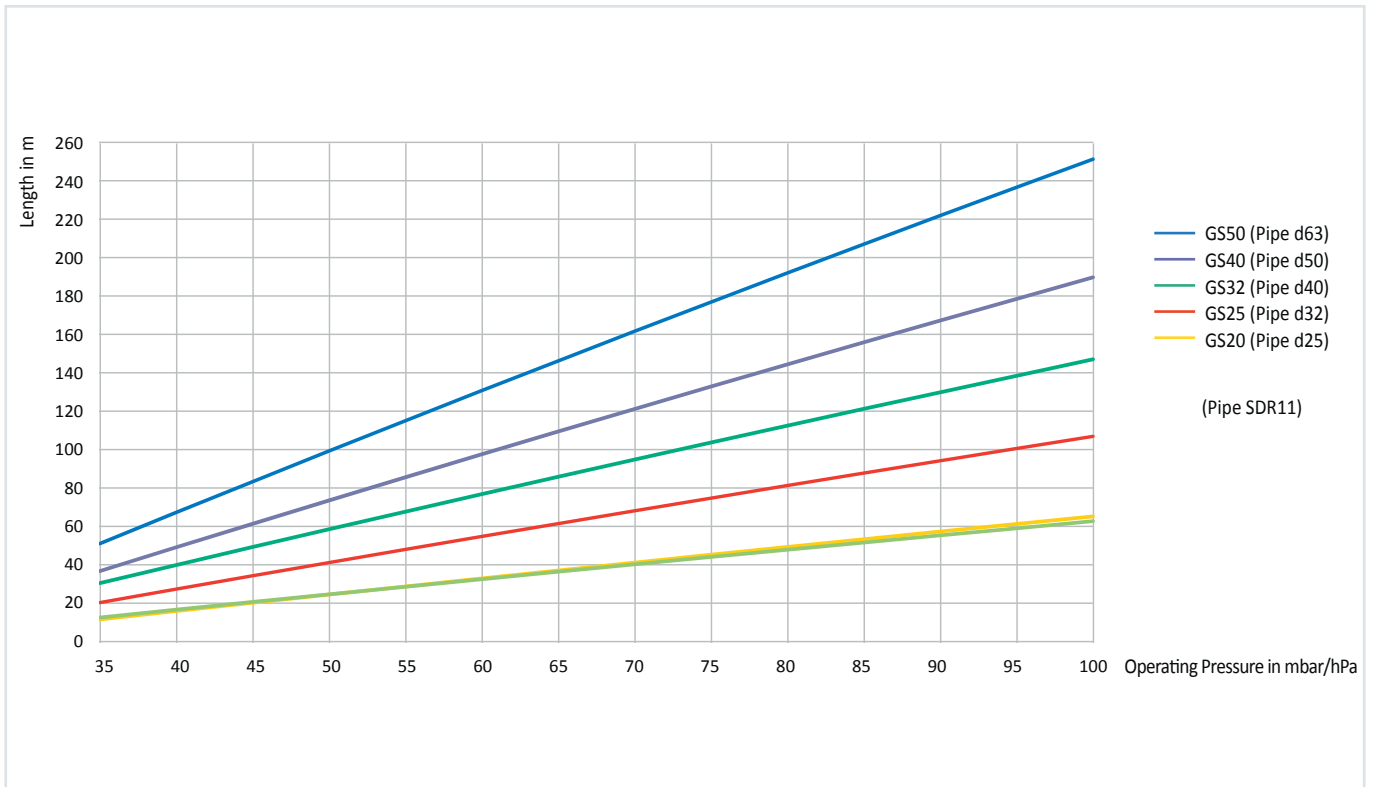

STANDARD VALUES FOR REOPENING TIME OF SENTRY GS..Z (30 l/h at 1 bar / 0.1 MPa) PER METER LINE LENGTHS

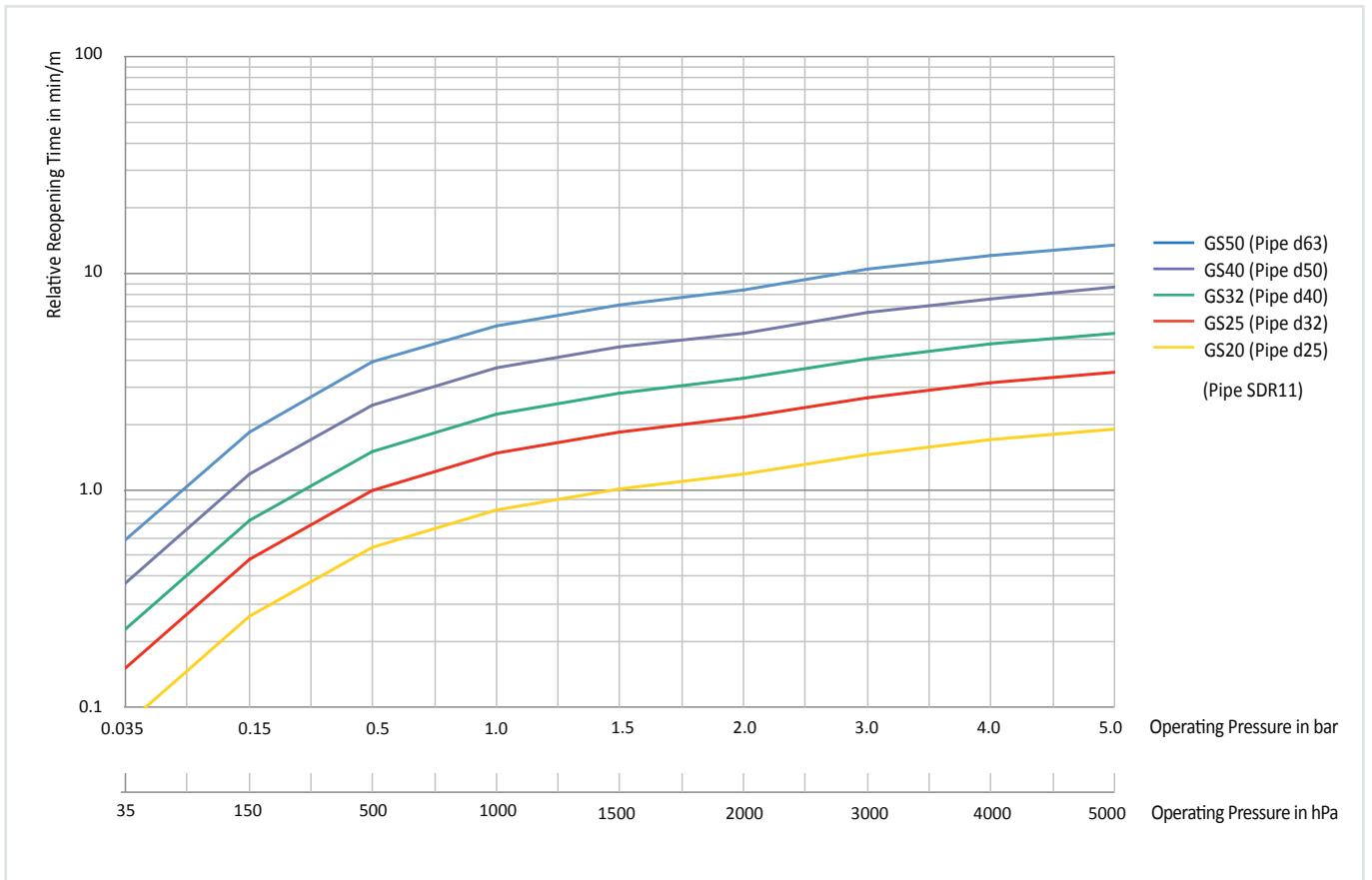

ORDER CODE

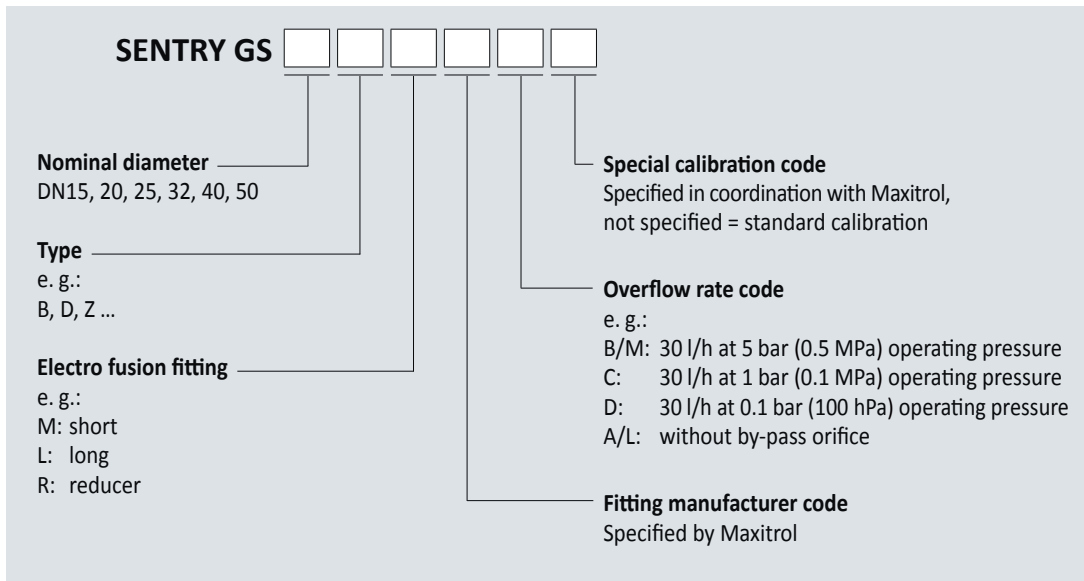

◀ Figure 8
Order code explanation

SENTRY GS FOR RESIDENTIAL INSTALLATION



PROVEN MILLIONS OF TIMES

Maxitrol's full line of excess flow valves, from DN15 to DN50, can be used in all mounting positions. Nominal flow rate ranges from 1.6 m³/h to 16 m³/h. For more information refer to "SENTRY GS Excess Flow Valves for Residential Installation" from Maxitrol.

SENTRY GS excess flow valves fulfill the German requirements of the *DVGW-TRGI 2018** and the *DVGW-TRF 2021**. They comply with the *Pressure Equipment Directive (2014/68/EU)*** and *DIN 30652-1:2021****. For protecting plastic pipe installations SENTRY GS are also available in combination with GT thermally activated shut-off devices.

MADE IN GERMANY

SENTRY GS excess flow valves and SENTRY GT thermally activated shut-off devices are produced at the company's European headquarters in Thale, Germany. Our products are 100 % tested to ensure consistently high quality.

YOUR FREE SIZING SOFTWARE

As a special service, Maxitrol offers free software for selecting the correct excess flow valve and calculating the pipe sizes. Request your free program online at www.maxitrol.com. This program is currently available only in German language.

◀ Figure 9

SENTRY GS-H-Z type K may be mounted either horizontally or vertically.

* *DVGW-TRGI 2018 and DVGW-TRF 2021:*

German mandatory technical regulation for the planning, construction, modification and servicing of natural gas (TRGI) and liquid gas (TRF) installations.

** *Pressure Equipment Directive (2014/68/EU):*

European regulation to harmonize national laws of Member States regarding the design, manufacture, testing, and conformity assessment of pressure equipment and assemblies.

*** *DIN 30652-1:2021*

Excerpt of DVGW-TRGI 2018 that prescribe the German standard for excess flow valves in residential installations.

▼ [Download the free sizing software here](#)



OTHER PRODUCTS

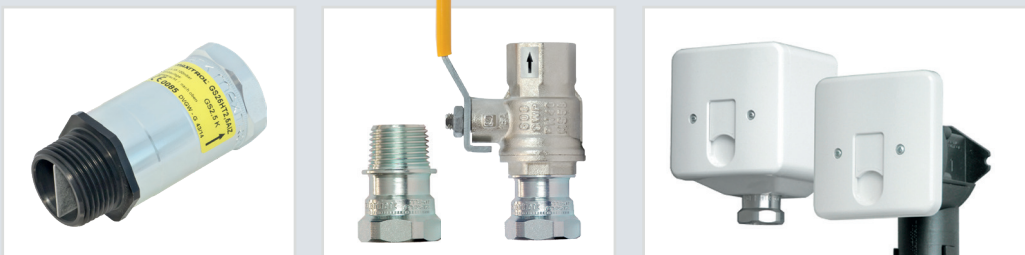

◀ Figure 10

SENTRY GS combined with a thermally activated shut-off device; SENTRY GT thermal cut-off devices; PLUG1 gas outlet (from left to right)

MAXITROL®

© 2025 Maxitrol GmbH & Co. KG, All Rights Reserved.

Maxitrol Company

23555 Telegraph Road
Southfield, MI 48033
USA

T: (+1) 248 356-1400
infoNA@maxitrol.com

Maxitrol GmbH & Co. KG

Warnstedter Str. 3
06502 Thale
Germany

T: (+49) 3947 400-0
infoEU@maxitrol.com

Maxitrol GmbH & Co. KG

Valleys Innovation Centre
Navigation Park
Abercynon CF45 4SN
United Kingdom

T: (+44) 1443 742-755
M: (+44) 7866 492-261
infoEU@maxitrol.com