

7th Edition

GAS PRESSURE REGULATOR & MODULATOR CATALOG

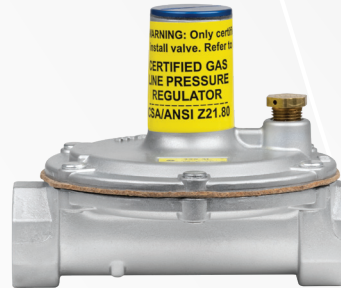
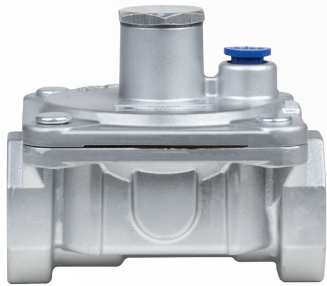
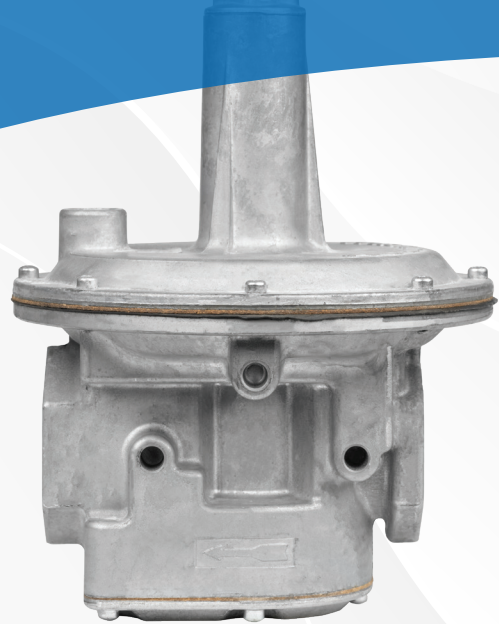
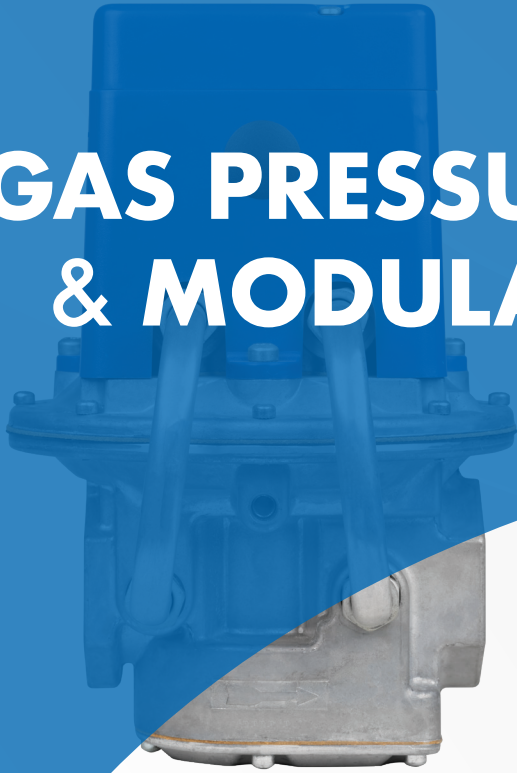

MAXITROL®

www.maxitrol.com

▲ WARNING

Service and installation must be performed by a trained/experienced service technician.

All products used with combustible gas **must** be installed and used **strictly** in accordance with the instructions of the Original Equipment Manufacturer (OEM) and with all applicable government codes and regulations, e.g. plumbing, mechanical, and electrical codes and practices. Maxitrol products should be installed and operated in accordance with Maxitrol Safety Warning Instructions.

Maxitrol Company is NOT responsible for any errors or omissions in reliance by anyone of any information set forth in this catalog without additional reference to local requirements and applicable ordinances or codes.

Other worldwide approvals and certifications available upon inquiry.



M/MR SERIES

Modulating Valves

For atmospheric, infrared, and direct fired burners, modulator and modulator/regulator valves provide precise, non-fluctuating, instantaneous temperature control without requiring a motor or mechanically driven butterfly valve. No external mechanical activation required. MR valve (only) performs dual function of modulation and pressure regulation. Applications include stabilized area heating, elevated heating, consistent higher baking/drying temperatures, and other process applications that require maintaining consistent temperatures.



MR212

Specifications

- Pipe Sizes** 3/8" to 3" threaded connections with NPT or ISO7-1 threads. 4" flange (212J) only
- Housing Material** All models: aluminum.
- Mounting** Must be mounted in upright position in horizontal pipe run, downstream of all other controls except high pressure cut-off switch if used (refer to MMR_MT_EN).
- NOTE:** All Maxitrol modulating valves should be installed and operated in accordance with Maxitrol Safety Warning Instructions (see SELMMRSR_MI_EN.FR.ES).
- Certifications** MR410, MR410H-1, MR510, MR510H-1, MR610, and MR610H-1: CSA certified to Z21.18 and CSA 6.3-M82.
- M511, M611, MR212D, E, and G: UL recognized for compliance to nationally published safety, construction, and performance standards in the U.S. and Canada.
- Fuel Gases** Natural, Manufactured, Mixed, Liquefied Petroleum and Liquefied Petroleum Gas Air Mixtures. H, H-1 models for use with Liquefied Petroleum and other applications.
- Rated Inlet Pressure** CSA Tested: MR410, MR410H-1, MR510, MR510H-1, MR610, MR610H-1, M411, M511, M611, M420, M420H, M520, M520H, M620, M620H, M451, M551, M651: 1/2 psi (3.4 kPa); CSA Rated: MR212D, MR212E, MR212G, MR212J: 5 psi (34 kPa).
- Upstream Pressure Regulator Required** YES: M valves
NO: MR valves
- Emergency Exposure Limits** MR410, MR410H-1, MR510, MR510H-1, MR610, MR610H-1, M411, M511, M611, M420, M420H, M520, M520H, M620, M620H, M451, M551, M651: 2.5 psi (17 kPa); MR251D, MR251E, MR251G, MR212D, MR212E, MR212G, MR212J: 12.5 psi (86 kPa)
- Ambient Temperature Ranges** All models: Operating: -40° to 125°F (-40° to 50°C); Non-operating: -50° to 185°F (-45° to 85°C)
- Vent** M411, M511, M611, M420, M520, M620, M420H, M520H, M620H, MR410 (H)(-1), MR510(H)(-1), MR610(H)(-1), M551, M651: Vertical vent outlet 1/8" NPT – 12A06 installed.
- Models MR212 and MR251: Two vents located in upper housing, both equipped with vent limiting means.

Model Designations

Direct Fired (Negative pressure/pull through): M411, M511, M611, MR212D, MR212E, MR212G, MR212J.

Direct Fired (Positive pressure/push through): MR212D-1, MR212E-1, MR212G-1, MR212J-1.

Indirect Fired (Valves designed to operate on indirect fired atmospheric burner applications): M420, M520, M620, M451, M551, MR251D, MR251E, MR251G, MR410, MR510, MR610. 'H' Suffix Models designed with wider modulation span for use with LP (liquid propane gas) and other applications: MR410H-1, MR510H-1, MR610H-1, M420H, M520H, M620H.

Capacity

NOTE: For flows in excess of those shown below, consult with Maxitrol Company.

Model	Pipe Size	Flow Rate in CFH (m ³ /h)	100 (2.83)	150 (4.25)	200 (5.66)	250 (7.1)	300 (8.5)	350 (9.9)	400 (11.3)	450 (12.7)	500 (14.2)	600 (17.0)	700 (19.8)	750 (21.2)	Min. Flow
MR410 MR410H-1 M411*	3/8 X 3/8	Pressure Drop in inches w.c. (Pa)	0.33 (82)	0.75 (188)	--	--	--	--	--	--	--	--	--	--	5-90 (0.14-2.5)
M420* M420H* M451	1/2 X 1/2		0.27 (67)	0.61 (153)											
MR510 MR510H-1 M511*	1/2 X 1/2		--	0.17 (42)	0.30 (75)	0.47 (118)	0.67 (168)	0.92 (230)	--	--	--	--	--	--	5-125 (0.14-3.5)
M520* M520H* M551	3/4 X 3/4		--	0.12 (30)	0.21 (52)	0.32 (80)	0.47 (118)	0.64 (160)	0.83 (207)	--	--	--	--	--	5-185 (0.14-5.2)
MR610 MR610H-1	3/4 X 3/4		--	--	--	0.14 (35)	0.20 (50)	0.27 (67)	0.36 (90)	0.45 (113)	0.56 (140)	0.81 (203)	--	--	10-330 (0.28-9.3)
M620* M620H* M651	1 X 1		--	--	--	0.12 (30)	0.16 (40)	0.22 (55)	0.29 (72)	0.37 (92)	0.45 (113)	0.66 (165)	0.90 (225)	1.00 (250)	

* Models to which min. flow applies. (Minimum flow maximum calculated $\Delta P = 3.5''$ w.c. [single by-pass])

M/MR SERIES

Modulating Valves

Capacity

NOTE: For flows in excess of those shown below, consult with Maxitrol Company.

Model	Pipe Size	Flow Rate in CFH (m ³ /h)	100 (2.83)	150 (4.25)	200 (5.66)	300 (8.5)	400 (11.3)	500 (14.2)	600 (17.0)	700 (19.8)	800 (22.7)	900 (25.5)	1000 (28.3)	CSA Listed	Min. Flow
M611*	3/4 x 3/4	Pressure Drop in inches w.c. (Pa)	0.02 (5)	0.06 (15)	0.09 (23)	0.20 (50)	0.36 (90)	0.56 (140)	0.81 (203)	1.10 (275)	1.45 (363)	1.83 (458)	--	1000	10-330 (0.28-9.3)
	1 x 1		0.02 (5)	0.05 (12)	0.07 (18)	0.16 (40)	0.29 (72)	0.46 (115)	0.66 (165)	0.90 (225)	1.18 (295)	1.50 (375)	1.85 (463)		

Model	Pipe Size	Flow Rate in CFH (m ³ /h)	1000 (28.3)	1500 (42.5)	2000 (56.5)	2500 (70.8)	3000 (85.0)	3500 (99.0)	5000 (142)	6000 (170)	7000 (198)	10000 (283)	11000 (311)	CSA Listed	Min. Flow Applies to MR212's only
MR212D* MR251D	1 x 1	Pressure Drop in inches w.c. (Pa)	1.9 (475)	2.9 (725)	4.9 (1225)	6.2** (1550)	--	--	--	--	--	--	--	2250	25-300 (0.71-8.5)
	1 1/4 x 1 1/4		1.7 (425)	2.3 (575)	3.1 (775)	4.8 (1200)	5.9** (1475)	--	--	--	--	--	--	2750	
	1 1/2 x 1 1/2		1.7 (425)	2.2 (550)	2.9 (725)	3.9 (975)	5.4 (1350)	--	--	--	--	--	--	3000	
MR212E*	1 1/2 x 1 1/2		--	--	1.9 (475)	2.4 (600)	2.9 (725)	3.5 (875)	6.0** (1500)	--	--	--	--	4750	25-300 (0.71-8.5)
MR251E	2 x 2		--	--	1.9 (475)	2.1 (525)	2.4 (600)	2.7 (675)	5.5 (1375)	6.0** (1500)	--	--	--	5250	
MR212G*	2 1/2 x 2 1/2		--	--	--	--	--	1.9 (475)	2.2 (550)	2.6 (650)	3.0 (750)	6.1 (1525)	--	10000	50-450 (1.4-12.7)
MR251G	3 x 3	--	--	--	--	--	--	2.1 (525)	2.3 (575)	2.6 (650)	4.6 (1150)	5.6 (1400)	11000	--	

Model	Pipe Size	Flow Rate in CFH (m ³ /h)	6000 (170)	8000 (227)	10000 (283)	12000 (340)	14000 (397)	16000 (397)	18000 (510)	20000 (566)	22000 (623)	24000 (680)	27000 (765)	30000 (850)	Min. Flow
MR212J	4 x 4	Pressure Drop in inches w.c. (Pa)	1.9 (475)	2.1 (525)	2.4 (600)	2.7 (675)	3.1 (775)	3.6 (900)	4.5 (1125)	5.4 (1350)	6.6 (1650)	7.8 (1950)	9.9 (2475)	12.4 (3100)	100-1000 (3.0-28.3)

*U.L. recognized

**Pressure Drop figures derived from CSA Maximum Listed Capacities in far right column (not flow at column top).

M/MR Series Applications Table

Model	Max. Current Draw (amps)	Application	Function	CSA Tested* Inlet Pressure	Inlet Pressure Operating Limits	Upstream Pressure Regulator Required	Maximum Emergency Exposure	Output Control Means Standard Factory Setting (if applicable)
M411 M511 M611	0.4 0.5 0.6	Direct Fired (Negative Pressure) Burners	Increase in voltage corresponds to increase in outlet pressure	1/2 psi (3.4 kPa)	Upstream pressure regulator setting	Yes	2.5 psi (17 kPa)	Low Fire: adjustable orifice bypass High Fire: upstream pressure regulator setting less pressure drop NOTE: 7" w.c. (1.7 kPa) max outlet pressure
M420 M420H M520 M520H M620 M620H	0.4 0.7 0.5 0.85 0.6 1.0	Atmospheric Burners H Models for higher outlet pressures (such as LP applications)	Increase in voltage corresponds to increase in outlet pressure	1/2 psi (3.4 kPa)	Upstream pressure regulator setting	Yes	2.5 psi (17 kPa)	Low Fire: adjustable orifice bypass High Fire: upstream pressure regulator setting less pressure drop NOTE: 7" w.c. (1.7 kPa) max outlet pressure NOTE: H models: 11" w.c. (2.7 kPa) max outlet pressure
M451 M551 M651	0.4 0.5 0.6	Atmospheric Burners - where higher outlet pressures are needed	Increase in voltage corresponds to increase in outlet pressure	1/2 psi (3.4 kPa)	Upstream pressure regulator setting	Yes	2.5 psi (17 kPa)	Low Fire: spring adjustment Std. Model: 1.2" - 2.5" w.c. (0.30-0.62 kPa) "-1" models: 2" - 4.5" w.c. (0.50-1.1 kPa) High Fire: upstream pressure regulator setting less pressure drop
MR251D MR251E MR251G	0.4	Atmospheric Burners - where higher outlet pressures are needed	Increase in voltage corresponds to increase in outlet pressure	--	5 psi (34 kPa)	--	12.5 psi (86 kPa)	Low Fire: spring adjustment 2" - 4.5" w.c. (0.50-1.1 kPa) High Fire: maximum 7" w.c. (1.7 kPa) above minimum setting
MR212D MR212E MR212G MR212J	0.4	Direct Fired (Negative Pressure) Burners	Increase in voltage corresponds to increase in outlet pressure	5 psi** (34 kPa)	5 psi (34 kPa)	--	12.5 psi (86 kPa)	Low fire: adjustable orifice bypass High fire: spring adjustment High Fire Setting: Std. model: 2 - 5" w.c. (0.50-1.25 kPa) "-2" model: 2" - 5" w.c. (0.50-1.25 kPa) reduced to 0-3" w.c. (0-0.75 kPa)
MR410 MR410H-1 MR510 MR510H-1 MR610 MR610H-1	0.4 0.7 0.5 0.85 0.6 1.0	Atmospheric Burners H-1 models for higher outlet pressure (such as for LP applications)	Decrease in voltage corresponds to increase in outlet pressure	1/2 psi** (3.4 kPa)	1 psi (7 kPa)	--	2.5 psi (17 kPa)	Low fire: spring adjustment High fire: spring adjustment Std. model: 3" - 5" w.c. (0.75-1.25 kPa) max-4" w.c. (1.0 kPa) "-1" model: min-1.5" w.c. (0.38 kPa) max-4" w.c. (1.0 kPa) 'H-1' model: min outlet pressure = 1.75" w.c. (0.44 kPa) max outlet pressure = 11" w.c. (2.7 kPa) NOTE: 'H-1' models: 7.5" to 12" w.c. (1.87 to 3 kPa) max outlet pressure

* Where no ANSI standard currently exists, Maxitrol Controls have been CSA tested for use as a component of Maxitrol Selectra® systems.

**CSA Rated Inlet Pressures are established by ANSI Z21.18, CSA 6.3, and CSA 6.5 standards where applicable.

M/MR SERIES

Modulating Valves

Dimensions

Model	Swing Radius	Dimensions - Expressed in Inches (mm)			
		A	B	C	D
MR410, MR410H-1, M411, M420, M420H, M451	3.1 (79)	3.9 (100)	2 (51)	2.5 (54)	0.9 (24)
MR510, MR510H-1, M511, M520, M520H, M551	4.3 (109)	5.3 (135)	3.25 (83)	3.4 (86)	1.2 (30)
MR610, MR610H-1, M620, M620H, M651	5.7 (145)	7.1 (180)	3.9 (99)	4 (102)	1.5 (37)
M611	6.2 (158)	7.7 (196)	3.9 (99)	4 (102)	1.5 (37)

NOTE: Dimensions are maximums and to be used only as an aid in designing clearance for the valve. Actual production dimensions may vary somewhat from those shown.

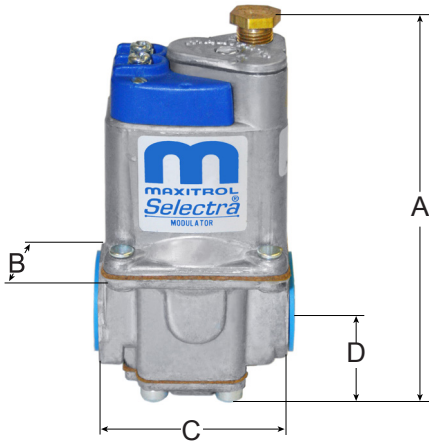

MR410, MR410H-1, M411,
M420, M420H, M451

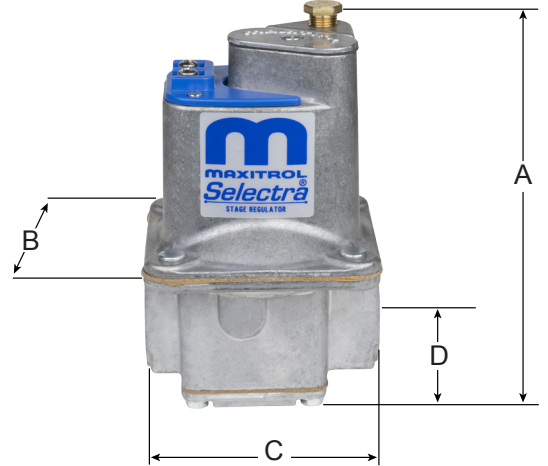

MR510, MR510H-1, M511,
M520, M520H, M551

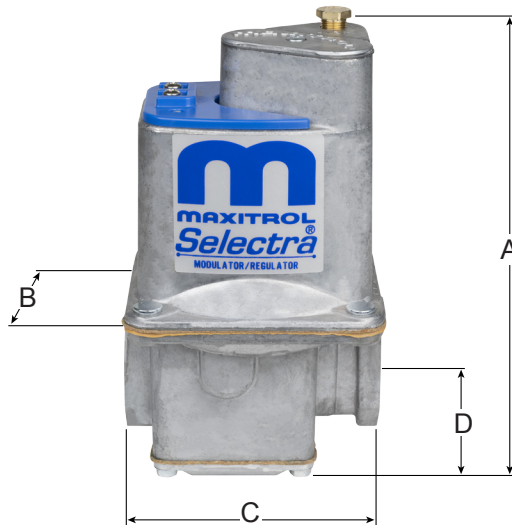

MR610, MR610H-1, M611,
M620, M620H, M651

Dimensions

Model	Swing Radius	Dimensions - Expressed in Inches (mm)			
		A	B	C	D
MR212D, MR251D	8.1 (206)	10.2 (259)	7 (178)	5.5 (140)	2.3 (59)
MR212E, MR251E	8.6 (218)	11.25 (286)	9.1 (232)	8 (203)	3 (76)
MR212G, MR251G	10.4 (264)	14.75 (375)	13.5 (343)	11.75 (298)	4.6 (118)
MR212J	--	24 (610)	21.5 (546)	13.9 (352)	5.9 (149)

NOTE: Dimensions are maximums and to be used only as an aid in designing clearance for the valve. Actual production dimensions may vary somewhat from those shown.

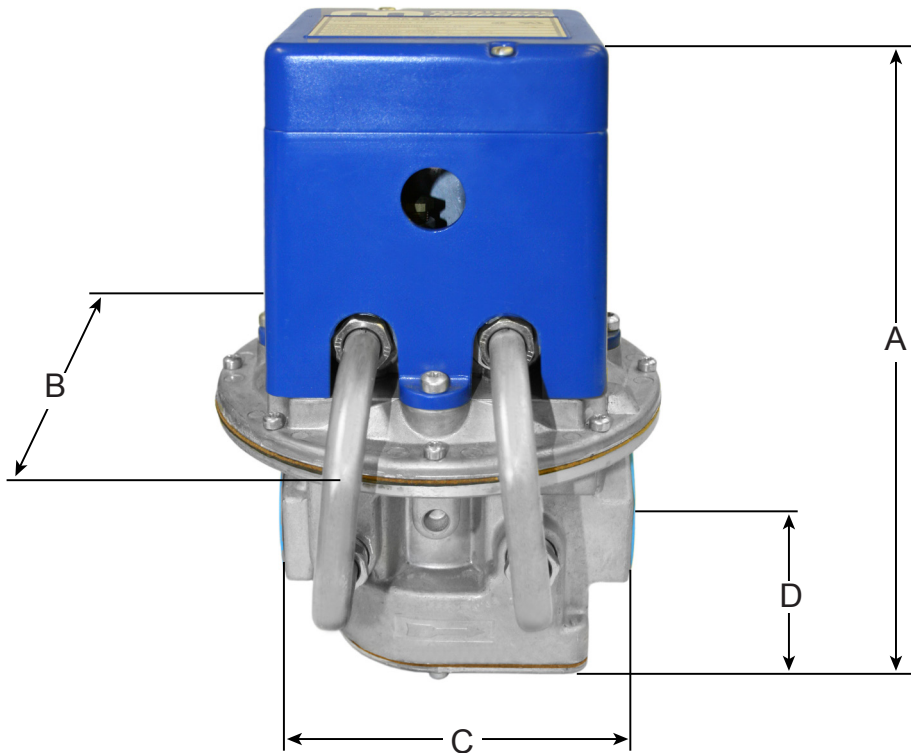

M/MR SERIES

Modulating Valves

M Series

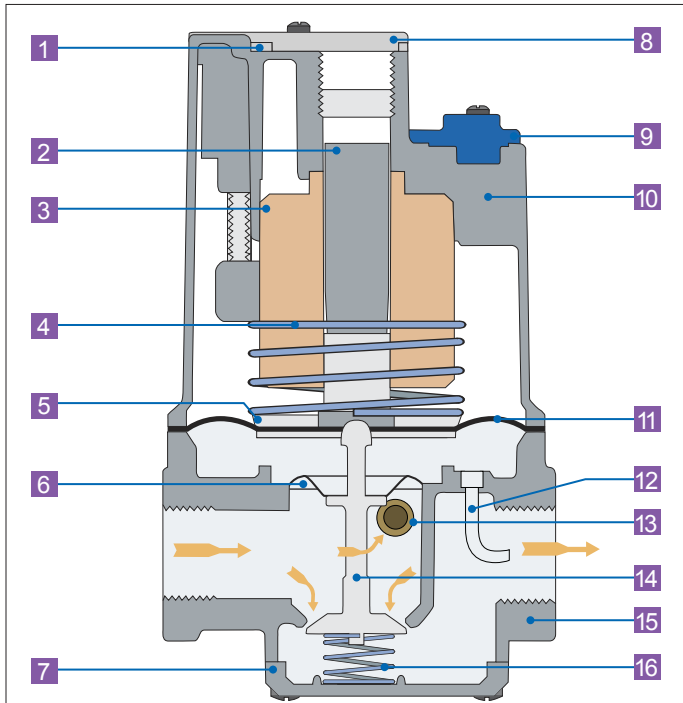

- | | | | |
|----|---------------------|----|----------------|
| 1 | Seal Cap Gasket | 11 | Diaphragm |
| 2 | Plunger | 12 | Sensing Tube |
| 3 | Solenoid | 13 | Bypass |
| 4 | Spring | 14 | Stem and Valve |
| 5 | Diaphragm Plates | 15 | Bottom Housing |
| 6 | Balancing Diaphragm | 16 | Counter Spring |
| 7 | Bottom Plate | | |
| 8 | Seal Cap | | |
| 9 | Wire Terminal | | |
| 10 | Top Housing | | |

MR Series

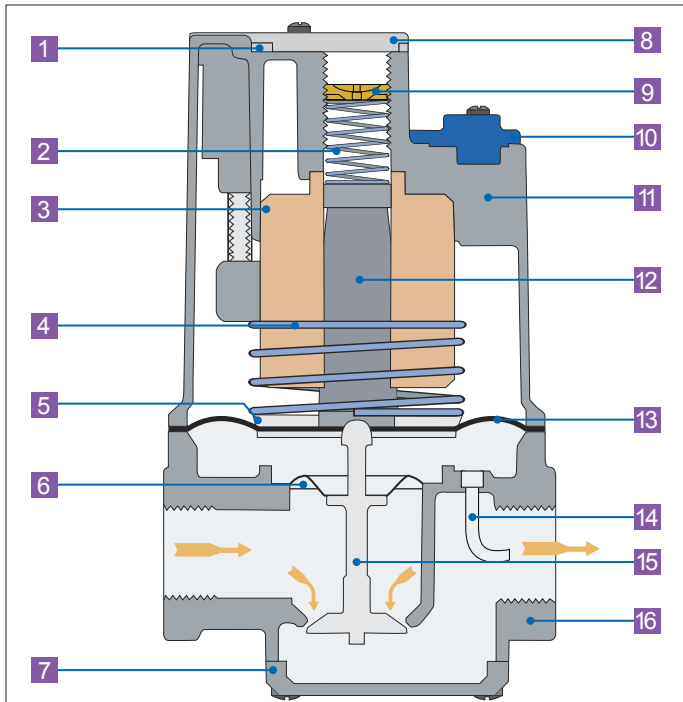

- | | | | |
|----|---------------------|----|----------------|
| 1 | Seal Cap Gasket | 11 | Top Housing |
| 2 | Plunger | 12 | Plunger |
| 3 | Solenoid | 13 | Diaphragm |
| 4 | Spring | 14 | Sensing Tube |
| 5 | Diaphragm Plates | 15 | Stem and Valve |
| 6 | Balancing Diaphragm | 16 | Bottom Housing |
| 7 | Bottom Plate | | |
| 8 | Seal Cap | | |
| 9 | Adjusting Screw | | |
| 10 | Wire Terminal | | |

NOTE: Diagrams are graphical representations only and may differ from actual product.

NOTE: Maxitrol offers application specific control systems for M/MR Series valves.

Consult Maxitrol or see MMR_MT_EN to determine which system suits your application.

MR212

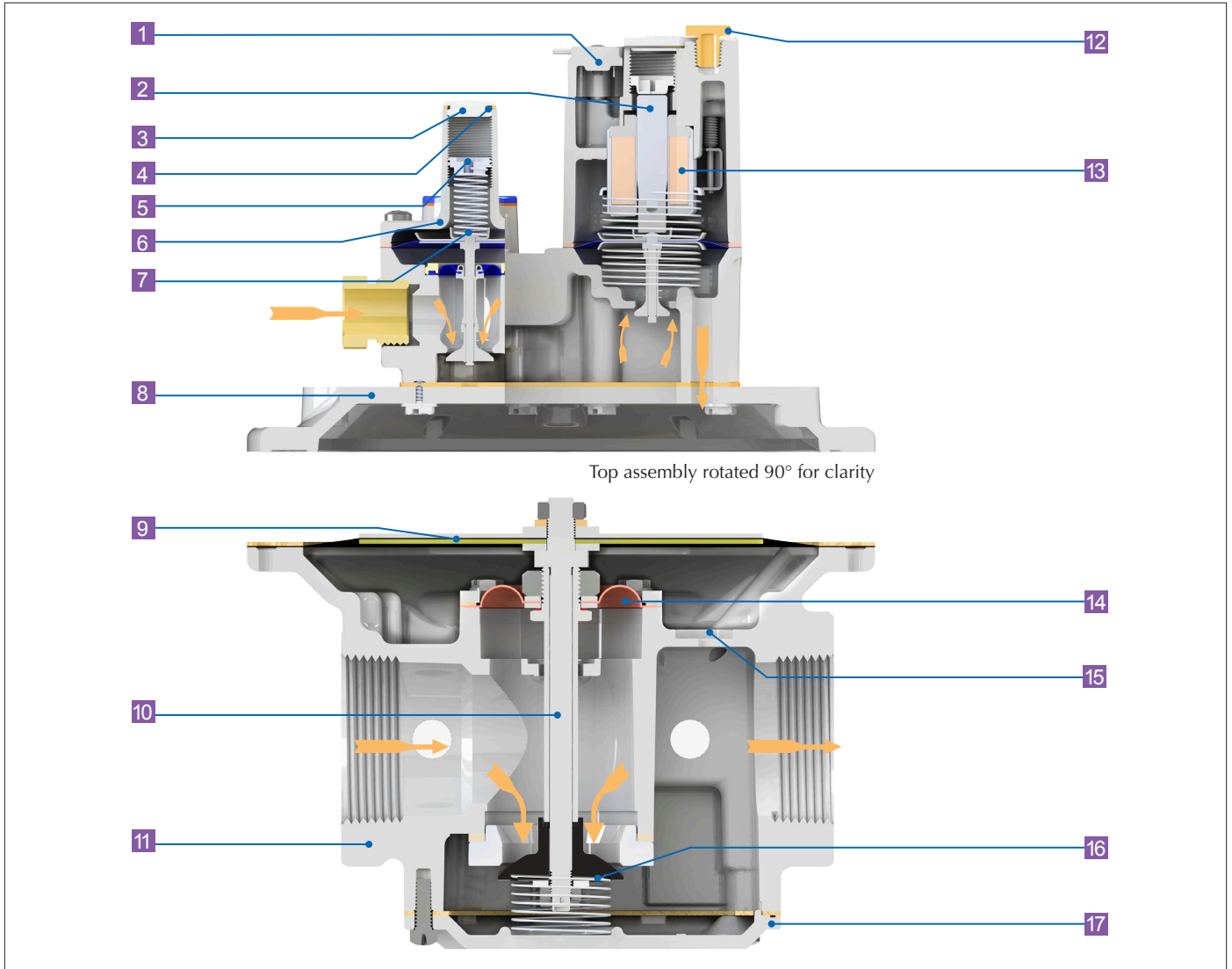

NOTE: Diagrams are graphical representations only and may differ from actual product.

1	Wire Terminal	8	Top Housing	15	Sensing Hole
2	Plunger	9	Regulating Diaphragm	16	Counter Spring
3	Seal Cap	10	Main Stem and Valve	17	Bottom Plate
4	Seal Cap Gasket	11	Bottom Housing		
5	Adjusting Screw	12	Vent Limiter		
6	Stack	13	Solenoid		
7	High Fire Spring	14	Balancing Diaphragm		