

7th Edition

GAS PRESSURE REGULATOR & MODULATOR CATALOG

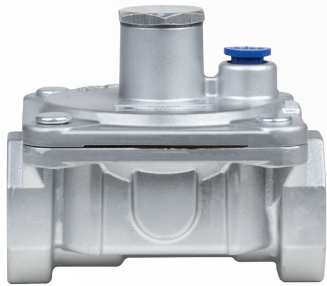
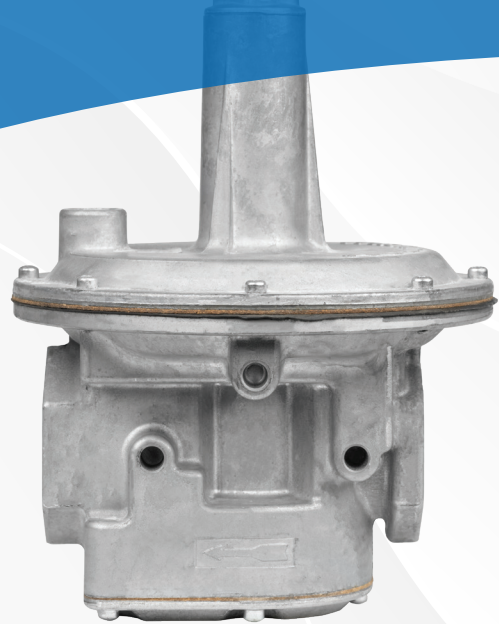
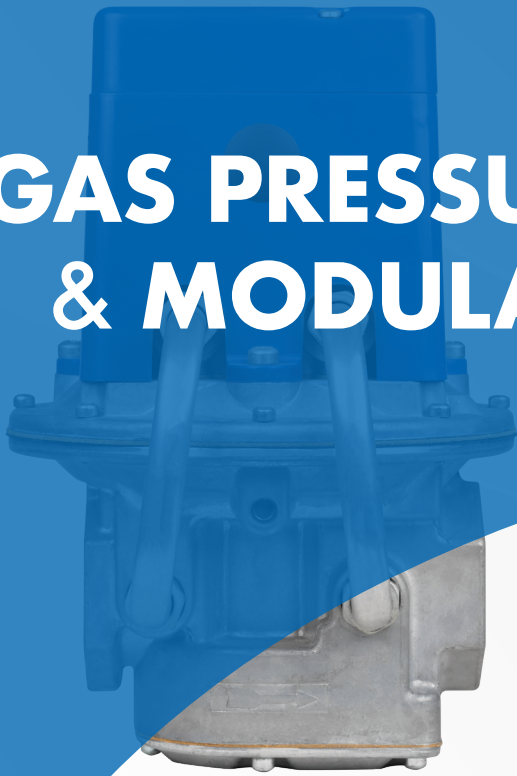

MAXITROL®

www.maxitrol.com

⚠ WARNING

Service and installation must be performed by a trained/experienced service technician.

All products used with combustible gas **must** be installed and used **strictly** in accordance with the instructions of the Original Equipment Manufacturer (OEM) and with all applicable government codes and regulations, e.g. plumbing, mechanical, and electrical codes and practices. Maxitrol products should be installed and operated in accordance with Maxitrol Safety Warning Instructions.

Maxitrol Company is NOT responsible for any errors or omissions in reliance by anyone of any information set forth in this catalog without additional reference to local requirements and applicable ordinances or codes.

Other worldwide approvals and certifications available upon inquiry.



HF2000 SERIES

Gas and Air Filters

Gas and air filters protect downstream controls (regulators, automatic shut-off valves) from particulate contamination. Recommended for use upstream of fittings, regulators, and controls. Applications for the residential, commercial cooking, process heating, and industrial burner industries. The unique filter mat material will not allow particle infiltration over 0.05mm (50 microns).



GF60

Specifications

- Pipe Sizes** 1/2" to 2" threaded connections with NPT or ISO 7-1 threads.
- Housing Material** GF40, GF60, GF80: aluminum.
- Filter Mat Material** Polypropylene fleece
- Micron Rating** 0.05mm (50 microns)
- Mounting Position** Suitable for multi-positional mounting, preferably with lid facing down or to the side to facilitate removal of debris during maintenance.

NOTE: All Maxitrol gas filters should be installed and operated in accordance with Maxitrol Safety Warning Instructions (see GF_IO_EN_HF2000).
- Approvals**..... CE
- Construction and Design** Function according to DIN 3386, Gas Appliances Regulation 2016/426/EU and Pressure Equipment Directive 97/23/EEC.
- Gas Types** Suitable for natural, manufactured, mixed gases, liquefied petroleum gases, LP gas-air mixtures, sewer gas, and air.
- Pressure Tap** Optional: Pressure tap (PF10) connections inlet and/or outlet side.
- Maximum Inlet Pressure** 60 psi (400 kPa)
- Maximum Pressure Drop** 1 kPa (10 mbar) (from this value, the filter mat must be changed). For more information see pressure drop chart, page 68.
- Ambient Temperature Ranges**..... -4 to 175°F (-20 to 80°C)
- Storage and Transport Temp** -58 to 175°F (-50 to 80°C)
- Filter Replacement** GF40 Models: KIT-GF40
GF60 Models: KIT-GF60
GF80 Models: KIT-GF80

Gas Filter Service Kit

(Incl. Insert, Gasket, and Screws)

Model	Service Kit Number	Min. Order Quantity
GF40M-44...	KIT-GF40M	10
GF60M-66...	KIT-GF60M	
GF60M-88...		
GF80M-1010...	KIT-GF80M	
GF80M-1212...		
GF80M-1616...		



Dimensions

NPT Model	ISO 7-1 Model	Pipe Size	Pressure
GF40-44	GF40M-44	1/2"	100 kPa, 400 kPa
GF60-66	GF60M-66	3/4"	100 kPa, 400 kPa
GF60-88	GF60M-88	1"	100 kPa, 400 kPa
GF80-1010	GF80M-1010	1 1/4"	100 kPa, 400 kPa
GF80-1212	GF80M-1212	1 1/2"	100 kPa, 400 kPa
GF80-1616	GF80M-1616	2"	100 kPa, 400 kPa

Outer Dimensions				
Model	Swing Radius	A	B	C
GF40	1.6" (41 mm)	2.1" (53 mm)	2.7" (69 mm)	2.3" (58 mm)
GF60	2.6" (66 mm)	3.7" (94 mm)	4.3" (109 mm)	3.7" (94 mm)
GF80	4" (102 mm)	6.2" (158 mm)	6.2" (163 mm)	6.4" (163 mm)

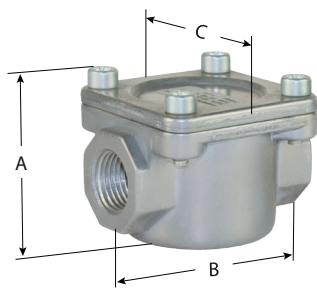

GF40

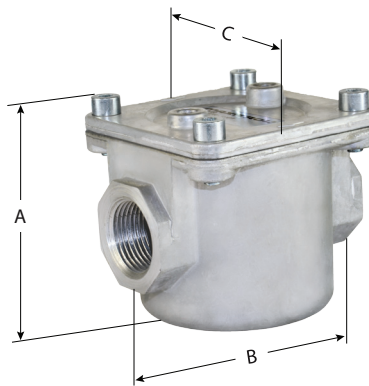

GF60

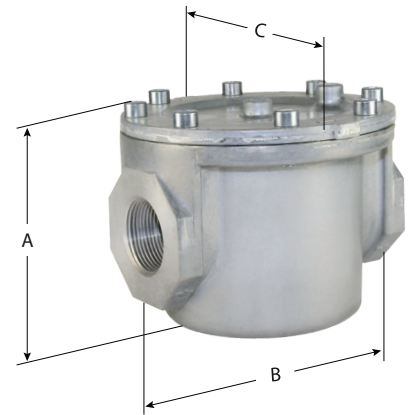

GF80

HF2000 SERIES

Gas and Air Filters

Pressure Drop Chart

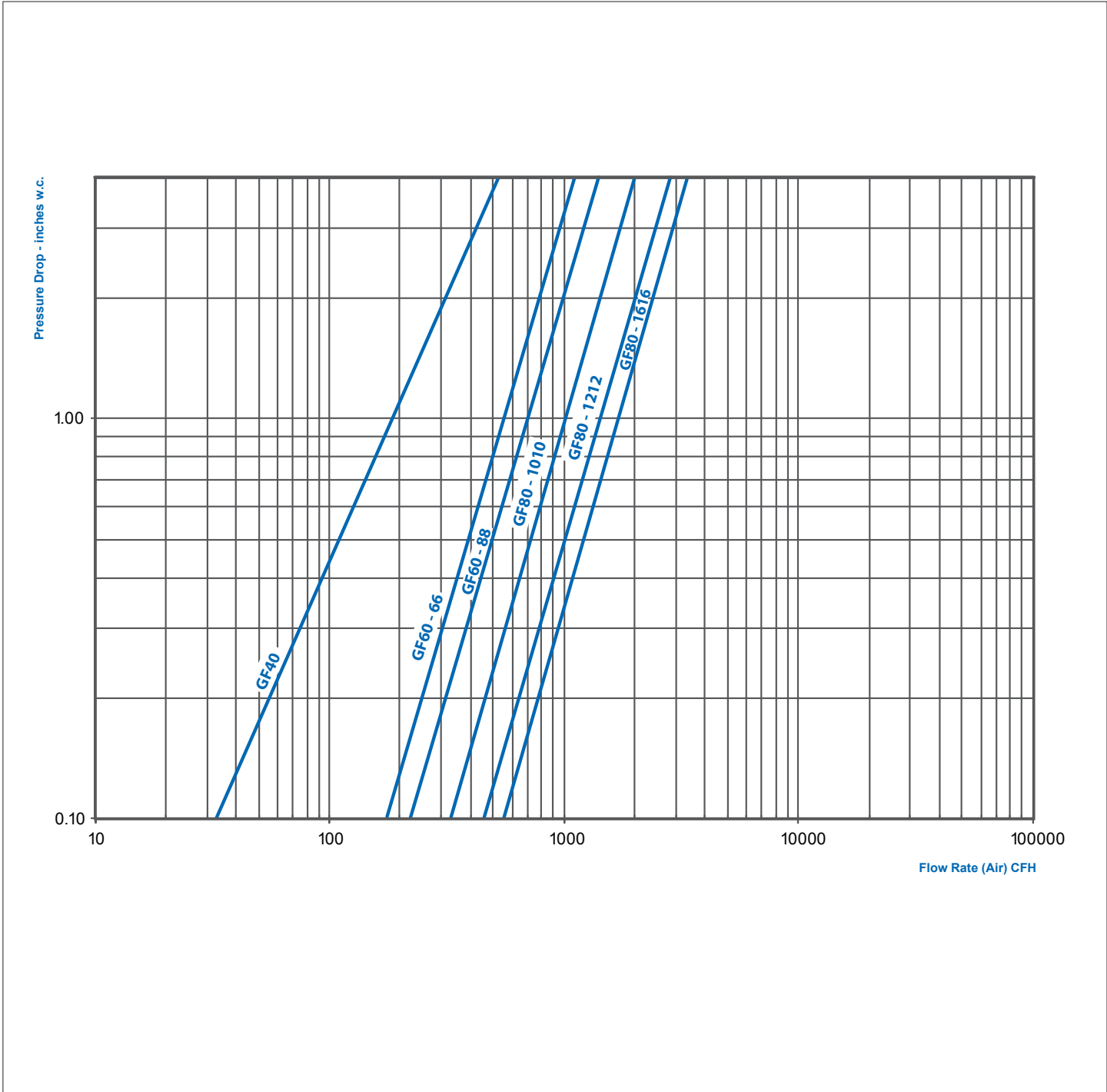

MAXITROL®

Maxitrol Company

23555 Telegraph Road
Southfield, MI 48033
USA

T: (+1) 248 356-1400
infoNA@maxitrol.com

Maxitrol GmbH & Co. KG

Valleys Innovation Centre
Navigation Park
Abercynon CF45 4SN
United Kingdom

T: (+44) 1443 742-755
M: (+44) 7866 492-261
infoEU@maxitrol.com

Maxitrol GmbH & Co. KG

Warnstedter Str. 3
06502 Thale
Germany

T: (+49) 3947 400-0
infoEU@maxitrol.com



SOCIAL MEDIA › LET'S CONNECT

Follow us for updates, interesting articles,
company news and product information.

